

SAM4S

ER-260/265 Electronic Cash Register AU

Operation and Programming Manual

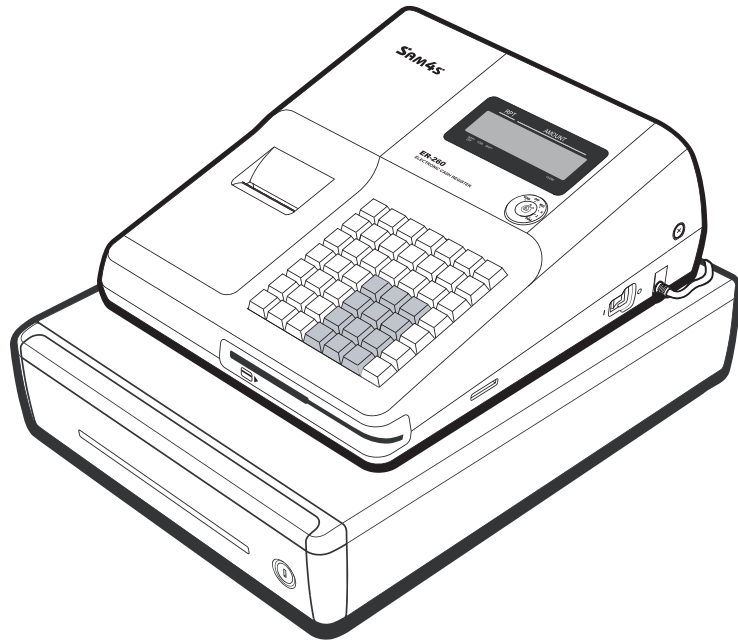

All specifications are subject to change without notice.

JK68-60980A Rev. 3.07 (Jun11)
From ER260/265 v01.000
Up to ER260/265 v05.000

ATTENTION

The product that you have purchased contains a rechargeable Ni-MH battery. This battery is recyclable. At the end of its useful life, under various state and local laws, it may be illegal to dispose of the battery into the municipal waste system.

Check with your local solid waste officials for details concerning recycling options or proper disposal.



WARNING

This is a Class A product. In a domestic environment this product may cause radio interference in which case the user may be required to take adequate measures.

Precaution Statements

Follow these safety, servicing and ESD precautions to prevent damage and to protect against potential hazards such as electrical shock.

1-1 Safety Precautions

1. Be sure that all built-in protective devices are replaced. Restore any missing protective shields.
2. When reinstalling the chassis and its assemblies, be sure to restore all protective devices, including nonmetallic control knobs and compartment covers.
3. Make sure there are no cabinet openings through which people - particularly children - might insert fingers and contact dangerous voltages. Such openings include excessively wide cabinet ventilation slots and improperly fitted covers and drawers.
4. Design Alteration Warning:
Never alter or add to the mechanical or electrical design of the SECR. Unauthorized alterations might create a safety hazard. Also, any design changes or additions will void the manufacturer's warranty.
5. Components, parts and wiring that appear to have overheated or that are otherwise damaged should be replaced with parts that meet the original specifications. Always determine the cause of damage or over-heating, and correct any potential hazards.
6. Observe the original lead dress, especially near the following areas: sharp edges, and especially the AC and high voltage supplies. Always inspect for pinched, out-of-place, or frayed wiring. Do not change the spacing between components and the printed circuit board. Check the AC power cord for damage. Make sure that leads and components do not touch thermally hot parts.
7. Product Safety Notice:
Some electrical and mechanical parts have special safety-related characteristics that might not be obvious from visual inspection. These safety features and the protection they give might be lost if the replacement component differs from the original - even if the replacement is rated for higher voltage, wattage, etc.
Components that are critical for safety are indicated in the circuit diagram by shading, () or (). Use replacement components that have the same ratings, especially for flame resistance and dielectric strength specifications. A replacement part that does not have the same safety characteristics as the original might create shock, fire or other hazards.

There is the danger of explosion if battery is incorrectly replaced.

Replace only with the same or equivalent type recommended by the manufacturer.

Dispose used batteries according to the manufacturer's instructions.

CAUTION

ATTENTION

Il y a danger d'explosion s'il y a un remplacement incorrect de la batterie.

Remplacer uniquement avec une batterie du même type ou d'un type équivalent recommandé par le constructeur.

Mettre au rebut les batteries usagées conformément aux instructions du fabricant.

SAFETY NOTICE: "For pluggable equipment, the socket-outlet shall be installed near the equipment and shall be easily accessible."

1-2 Servicing Precautions

WARNING: First read the-Safety Precautions-section of this manual. If some unforeseen circumstance creates a conflict between the servicing and safety precautions, always follow the safety precautions.

WARNING: An electrolytic capacitor installed with the wrong polarity might explode.

1. Servicing precautions are printed on the cabinet. Follow them.
2. Always unplug the units AC power cord from the AC power source before attempting to:
 - (a) Remove or reinstall any component or assembly
 - (b) Disconnect an electrical plug or connector
 - (c) Connect a test component in parallel with an electrolytic capacitor
3. Some components are raised above the printed circuit board for safety. An insulation tube or tape is sometimes used. The internal wiring is sometimes clamped to prevent contact with thermally hot components. Reinstall all such elements to their original position.
4. After servicing, always check that the screws, components and wiring have been correctly reinstalled. Make sure that the portion around the serviced part has not been damaged.
5. Check the insulation between the blades of the AC plug and accessible conductive parts (examples: metal panels and input terminals).
6. Insulation Checking Procedure: Disconnect the power cord from the AC source and turn the power switch ON. Connect an insulation resistance meter (500V) to the blades of AC plug.

The insulation resistance between each blade of the AC plug and accessible conductive parts (see above) should be greater than 1 megohm.
7. Never defeat any of the B+ voltage interlocks Do not apply AC power to the unit (or any of its assemblies) unless all solid-state heat sinks are correctly installed.
8. Always connect an instrument's ground lead to the instrument chassis ground before connecting the positive lead; always remove the instrument's ground lead last.

1-3 Precautions for Electrostatic Sensitive Devices (ESDs)

1. Some semiconductor (solid state) devices are easily damaged by static electricity. Such components are called Electrostatic Sensitive Devices (ESDs); examples include integrated circuits and some field-effect transistors. The following techniques will reduce the occurrence of component damage caused by static electricity.
2. Immediately before handling any semiconductor components or assemblies, drain the electrostatic charge from your body by touching a known earth ground. Alternatively, wear a discharging wrist-strap device. (Be sure to remove it prior to applying power - this is an electric shock precaution.)
3. After removing an ESD-equipped assembly, place it on a conductive surface such as aluminum foil to prevent accumulation of electrostatic charge.
4. Do not use Freon-propelled chemicals. These can generate electrical charges that damage ESDs.
5. Use only a grounded-tip soldering iron when soldering or unsoldering ESDs.
6. Use only an anti-static solder removal device. Many solder removal devices are not rated as anti-static; these can accumulate sufficient electrical charge to damage ESDs.
7. Do not remove a replacement ESD from its protective package until you are ready to install it. Most replacement ESDs are packaged with leads that are electrically shorted together by conductive foam, aluminum foil or other conductive materials.
8. Immediately before removing the protective material from the leads of a replacement ESD, touch the protective material to the chassis or circuit assembly into which the device will be installed.
9. Minimize body motions when handling unpackaged replacement ESDs. Motions such as brushing clothes together, or lifting a foot from a carpeted floor can generate enough static electricity to damage an ESD.

Contents

Getting Started	1
Using This Manual	1
Using Flowcharts.....	1
Unpacking.....	2
Installing the Paper	2
Basic Features and Functions	7
Standard Hardware	7
Optional Hardware	7
Software Features	7
Front Display	8
Rear Display	10
Display Messages	12
Control Lock	13
Keyboard	14
Memory Clear	16
Memory All Clear (RAM Clear)	16
Initial Clear (Status Clear).....	17
Operating Instructions	19
Function Key Descriptions	19
Clerk Operations	21
Clerk Sign On.....	21
Clerk Sign Off	21
Basic Operations	22
Registering Items.....	22
Repeating an Item.....	22
Registering Multiple Items	22
Department Registrations	23
Open Department	23
Preset Price Department	23
Department Repeat Entry	24
Multiplication	24
Department Multiplication with Decimal Point	25
Split Pricing.....	25
Single Item Department.....	26
PLU (Price Look Up) Registrations	27
Open PLU.....	27

Preset Price PLU.....	27
PLU Repeat Entry.....	27
PLU Multiplication.....	28
PLU Multiplication with Decimal Point.....	28
Split Pricing PLU	29
Percent Key (+% and -%) Operations.....	30
Preset Percent on a Department or PLU Item.....	30
Enter a Percent on a Department or PLU	30
Percent on Sale Total.....	31
Return Merchandise Registrations	32
Voids and Corrections	32
Void Last Item.....	32
Void Previous Item.....	33
Cancel.....	33
Void Position Operations	33
- (Minus) Key Registrations	34
No Sale Operations	35
Open Drawer	35
Non Add Number	35
Received On Account Operations.....	36
Paid Out Operations.....	36
Totaling a Cash Sale	37
Tendering a Cash Sale	37
Tendering a Check Sale.....	38
Totaling a Charge Sale	38
Totaling and Tendering.....	39
Subtotaling a Sale	39
Totaling a Cash Sale	39
Tendering a Cash Sale	39
Tendering a Check Sale.....	40
Totaling a Charge Sale	40
Check Cashing.....	41
Split Tender	41
Post Tender.....	42
Currency Conversion.....	43
Add Check.....	44
Receipt On/Off and Receipt on Request.....	45
Calculator Operation.....	47

X/Z Mode Reporting 49

Report Summary	49
Running a Report.....	49
Report Table	50
Electronic Journal (EJ) Table	51
Cash-In-Drawer Declaration.....	52
Declaring Cash	52
Setting Receipt/Journal Status	52

Service Mode Programming 53

Memory Allocation Scan	53
Program 60 - Memory Allocation Scan.....	53
EPROM Information.....	53
Program 50 - EPROM Information	53

PC Online Mode	53
----------------------	----

Program Mode Programming 55

Default Programming	55
Basic Programming	56
Setting the Date	56
Setting the Time	57
Programming Tax	58
Department Programming.....	59
Programming Department Status.....	59
Programming Department Entry Limit or Price	62
PLU (Price Look Up) Programming.....	64
Programming PLU Status.....	64
Programming PLU Entry Limit or Price	67
System Option Programming.....	69
System Option Table	70
Advanced Tax Programming	72
Tax Rate Programming.....	72
+% and -% Key Programming.....	74
- (Minus) Key Programming	75
CANCEL Key Programming.....	76
Programming the CANCEL Key.....	76
Currency Conversion Programming	77
Clerk Programming	78
Register Number Programming	80
Descriptor Programming	81
Alpha Overlay Method.....	81
Code Table Method.....	83
Customer Logo Descriptor	84
Department Descriptor	86
PLU Descriptor	88
Descriptor Programming Example	90
Program Scan.....	92
Department and Option Program Scan.....	92
PLU Programming Scan.....	92
Program Scan Example	93

Report Samples 95

Financial Report	95
Hourly Sales Report.....	97
PLU Report.....	98
Clerk Report	99
Cash-in-Drawer Report.....	100
Check-in-Drawer Report	100
System Balancing	101
Department Sales Total	101
Net Total.....	101
Gross Total.....	101
Grand Total	101

Getting Started

Using This Manual

Congratulations! You have selected a very flexible electronic cash register designed for years of reliable service. The *SAM4s ER-260/265* will fit many retail stores, shops and restaurants. It provides fast transaction processing, security, and detailed sales information.

- To Get Started turn to “**Quick Setup**”. This section covers unpacking, memory clearing, a few simple programming steps, and instructions for basic cash register transactions. All of the features of the *SAM4s ER-260/265* (except the clerk functions) operate immediately, without additional programming steps. In most cases, all the programming you need to do is covered in this section.
- For information about reports and balancing see “**Reports**”.

This manual also includes detailed information about many additional features that will help you solve the special calculation problems or security issues that you might face.

- For detailed programming instructions, see “**Program Mode Programming**”.
- For detailed operations sequences, see “**Operation Instructions**”.

Using Flowcharts

Flowcharts are used to supplement step by step instructions throughout this manual. For example, the following flowchart describes how to register \$1.00 into department 1:



This flowchart means:

1. Press numeric key **1**.
2. Press numeric key **0**.
3. Press numeric key **0**.
4. Press department **1**.

Follow the flowchart from left to right, pressing the keys in the order they are shown. Numeric keypad entries are shown as square keys. Department and function keys are shown as rectangular keys.

Unpacking

1. Unpack and unwrap the cash register.
2. Locate in the packing the following items:
 - 1 roll of paper
 - 1 rewind spindle
 - 1 set of control keys
 - This Operation and Programming Manual,
3. Remove the cardboard protectors from the cash drawer.
4. Plug the register into a grounded outlet (three prong), insert a control key and turn the key to the **REG** control lock position.

Installing the Paper

When you have an *ER-260/265* with EPROM v 05.000 and later, please follow the steps to install paper into the register.

1. Remove the printer cover.

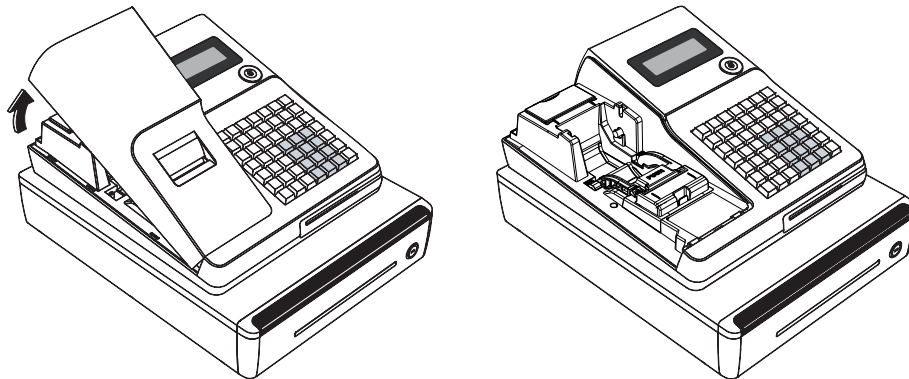

2. Push the yellow cap lever and lift up the platen roller.

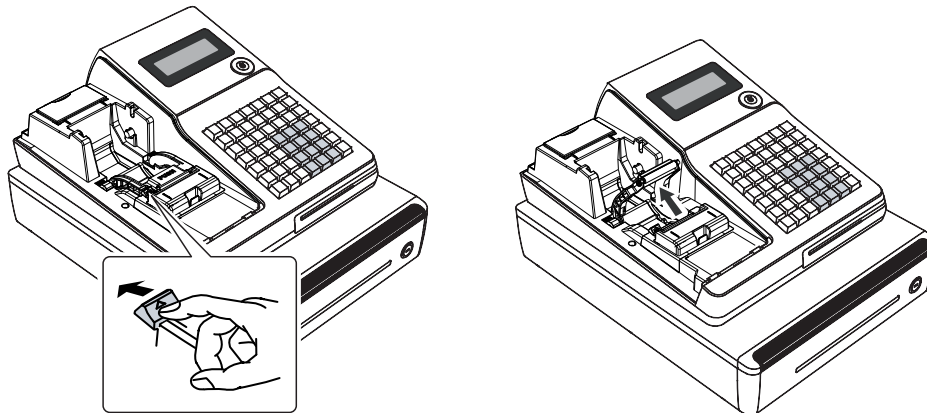

3. Load the paper and close the platen roller.

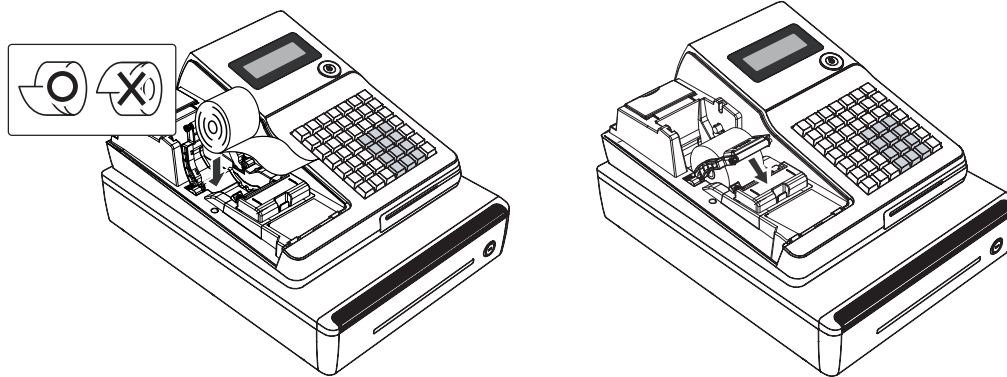

4. Close the platen roller firmly.

5. Tear off the excess paper and close the platen roller.

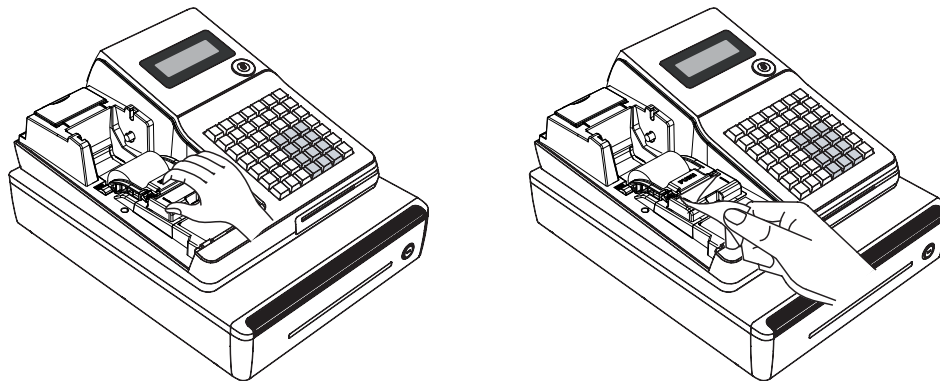

※If you wish to use the printer to print a sales journal, insert the paper into the paper take-up spool. Wind the paper two or three turns around the spool shaft and install the spool in the mount

A. If you use the ER-260/280 Series with 1-station, refer to below figure.

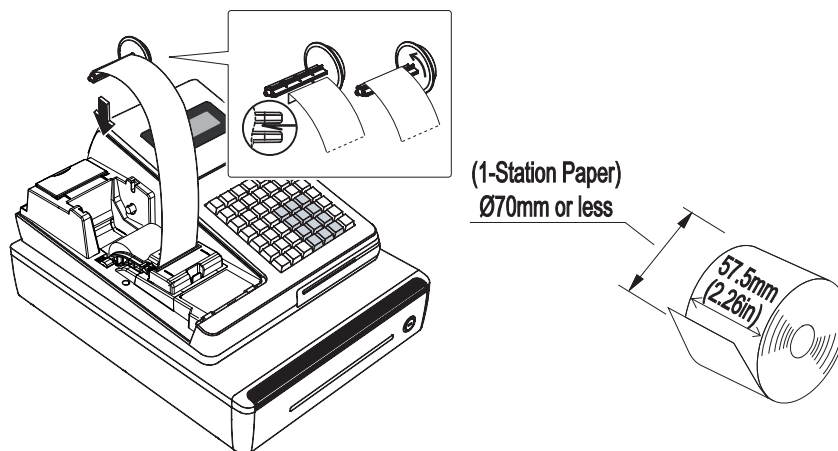

The earlier versions (GOD 01.013A and earlier) have different Printer Unit. Please refer to information below.

1. Remove the printer cover.

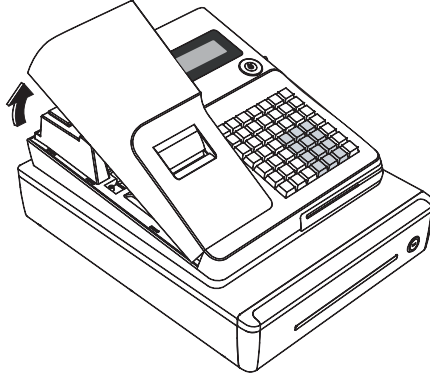

2. For proper feeding through the print head, cut or tear a straight even edge on the end of the paper roll. (Be sure to remove any paper with glue residue.) Place the paper roll in the paper holder so that the paper will feed from the bottom of the roll.

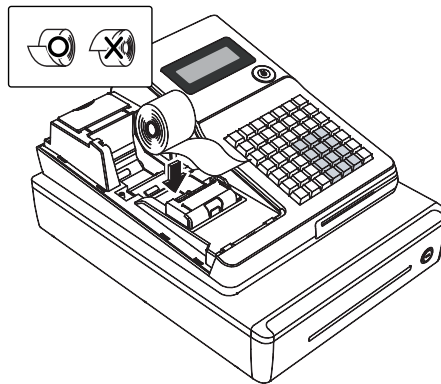

3. Insert the end of the paper into the paper slot.

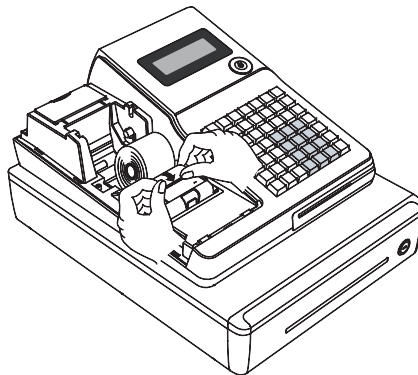

4. Close the paper lever. (ER-260/265 is possible to feed automatically when you rock the paper levers and insert paper). Replace the printer cover.

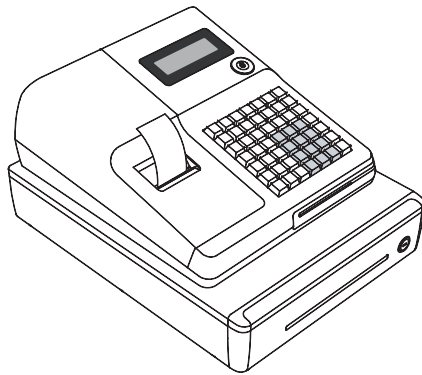
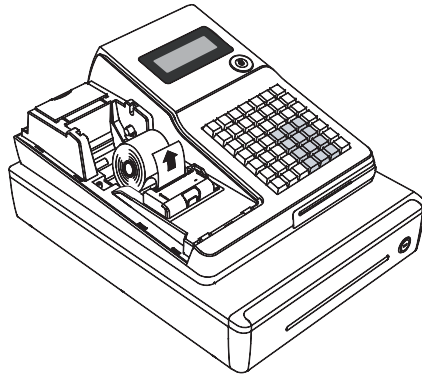

- ※ If you wish to use the printer to print a sales journal, insert the paper into the paper take-up spool. Wind the paper two or three turns around the spool shaft and install the spool in the mount.

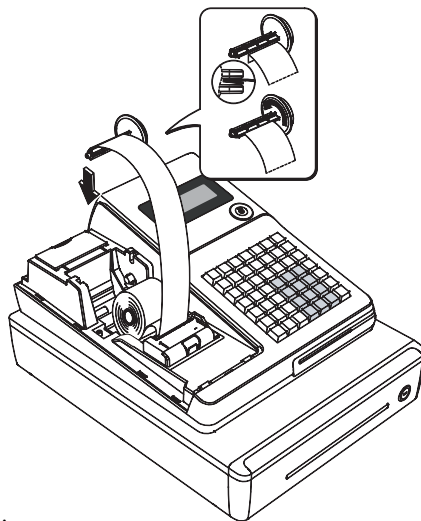

* In case of Paper Jam, refer to below figure.

A. Open the paper lever and open the cap printer.

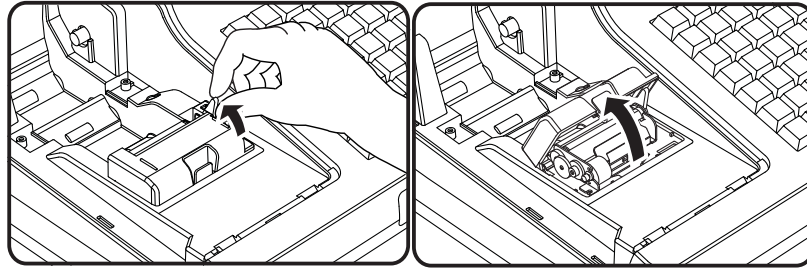

B. Remove the jamming paper. (Be carefull not to get burned in the hand because it is very hot in the cap printer.)

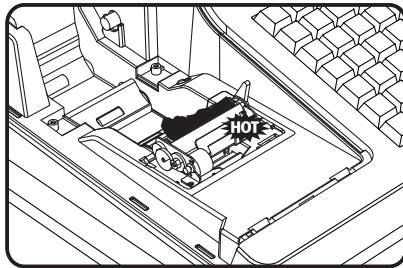

Basic Features and Functions

Standard Hardware

- Display: Ten position front and rear displays standard. Both displays are fixed to the housing.
- Keyboard
 - => **ER-260** Series: 48 position Raised Keyboard.
 - => **ER-265** Series: 48 position Flat Keyboard.
- 1 station Thermal 32-column printer.
- Cash Drawer
 - => **ER-265B**: Modern design cash drawer with 4 Bill / 4 Coin configuration.
 - => **ER-26xALB**: Sturdy Metal Cash Drawer with removable 4 Bill / 8 Coin drawer insert
- 7-position control lock.
- Standard customer display.

Optional Hardware

- Communication port (standard for **ER-26xRALB** models)
- PC Link.
- Kitchen Printer.

Software Features

- 15 Departments.
- 1000 PLUs.
- 18 Character programmable descriptors for Department s and PLU.

Front Display

DPT	RPT	AMOUNT
12	34	5678.90

DPT Indicates the department number of the registration (2 digits).

RPT Indicates the number of times an item has been repeated.

AMOUNT Displays the amount the amount of the item, subtotal or total.

CLERK If the clerk system is implemented, one of 10 lines illuminate indicating which clerk is active.

RPT

5 of items link to department 1 at \$2.50 each has been registered

DPT	RPT	AMOUNT
01	5	2.50

Subtotal

DPT	RPT	AMOUNT
5		12.50

Change Due

DPT	RPT	AMOUNT
[2.50

Total of Sale

DPT	RPT	AMOUNT
-		12.50

Negative Entry

2 of items link to department 1 total at \$5.00 has been void

DPT	RPT	AMOUNT
012		-5.00

Numbered Error Conditions

E8 represent Printer Error (No Paper)

DPT	RPT	AMOUNT
E8		0.00

Rear Display

The rear display is a 10 digit florescent display that allows your customer to monitor the transaction and view the sale total. The rear display is for easy customer viewing.

Rear Display Information

Item Count	The number of times an item has been repeated is displayed
Amount	The amount of the item, subtotal or total, is displayed in the rightmost portion of the display

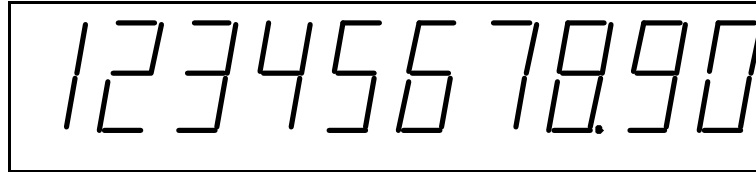

RPT

5 of items link to department 1 at \$2.50 each has been registered



Subtotal



Change Due



Total of Sale



Negative Entry

2 of items link to department 1 total at \$5.00 has been void



Numbered Error Conditions

E8 represent Printer Error (No Paper)

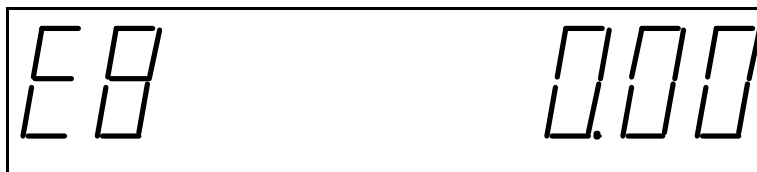

Display Messages

C	Change Due
E	Error
-	Negative entry
=	Total
E1	Input Error
E3	Printer Error (paper jam)
E4	Non Add # required
E5	Cash Declaration required
E6	Cash Drawer is open
E8	No Paper

Control Lock

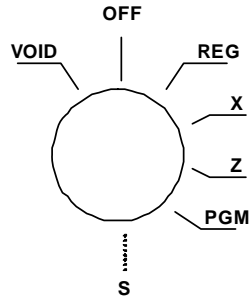

- VOID** Use to void (correct) items outside of a sale.
- OFF** The register is inoperable.
- REG** Use for normal registrations.
- X** Use to read register reports.
- Z** Use to read register reports and reset totals to zero.
- PGM** Use to program the register.
- S** The S Position is a **hidden position** reserved for dealer access.

The *SAM4s ER-260 Series* includes two sets of keys that may be used to access the following key lock positions.

Key	Positions Accessible						
	VOID	OFF	REG	X	Z	PGM	S
Removable		√	√				
REG		√	√				
VOID	√	√	√	√			
Z	√	√	√	√	√		
P	√	√	√	√	√	√	
C	√	√	√	√	√	√	√

Keyboard

The *ER-260 Series* keyboard includes 48 positions with default legends and key assignment as shown below. The keyboard legend sheet can be replaced by lifting the protective plastic cover and/or keycaps.

PAPER FEED	ADD CHECK	TAX	#/NS	CLERK	RA	PO
-	-%	+%	C/CONV	RETURN	VOID	CANCEL
1	6	11	CLEAR	X/TIME	PLU	CHARGE
2	7	12	7	8	9	CHECK
3	8	13	4	5	6	SUB TOTAL
4	9	14	1	2	3	CASH / TEND
5	10	15	0	00	•	

Alpha Keyboard Overlay - for EPROM v1.013A(& Later)

	M	T	V	X	Z	Back
F	L	S	U	W	Y	Space
E 1	K 6	R 11	CLEAR	X/TIME	PLU	Double
D 2	J 7	Q 12	7	8	9	CHECK
C 3	I 8	P 13	4	5	6	
B 4	H 9	O 14	1	2	3	CASH / TEND
A 5	G 10	N 15	0	00	•	

Alpha Keyboard Overlay - for EPROM v1.010 (& Earlier)

		Space	Double	Ü £ Ñ	Ø Å €	Í Ó Û
) * +	, - sp	^ ~	\ }	_ . Dbl	Ç Ä Å	É Ê Æ Ö
ABC 1	DEF 6	GHI 11	CLEAR	X / TIME	PLU	
JKL 2	MNO 7	PQR 12	7	8	9	CHECK
STU 3	VWX 8	YZ@ 13	4	5	6	
& # \$ 4	* / : 9	; < = 14	1	2	3	CASH / TEND
> ? [5] ! " ' 10	% { 15	0	00	•	

Memory Clear

WARNING: This is a one time procedure. Do not repeat this procedure after the cash register is programmed, it causes all programs and totals to be erased.

Memory All Clear (RAM Clear)

This step insures that the cash register is cleared of any totals or programming. After this procedure, the cash register is ready for programming and operation.

To Perform a Memory All Clear - reset memory completely

1. Unplug the register.
2. Turn the control lock to the **S** position (one past **PGM**).
3. Press and hold the **Subtotal** key on **the default keyboard layout**.
4. Continue to hold the **Subtotal** key while plugging the register into a power source.
5. After hear a **beep**, release the **Subtotal** key, then press **the upper left key (Paper Feed)** of the keyboard, then **the lower left key (Department 5)**, then **the upper right key (PO)**, and finally press **the lower right key (Cash/Tend)**.

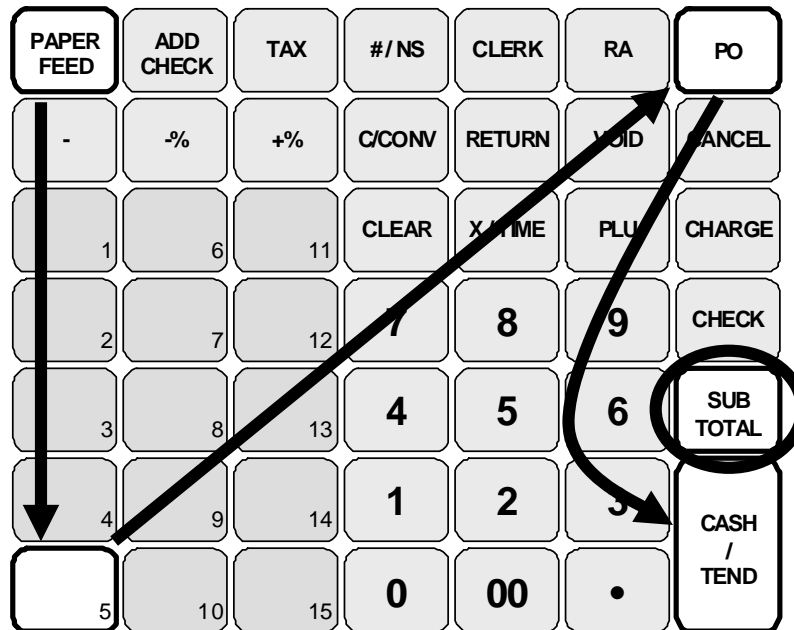

6. “=====.” will be shown on the display. After a short delay, the printer will print the message: **"RAM ALL CLEAR OK!"** Memory is cleared and the default program is installed. This is followed with the EPROM info.
7. The display will show **"PLU INI"**. By press **CASH** key once, the display will show **"====CC=.=.=."**. After a short waiting, **"PLU INITIALIZATION COMPLETEED!"** will print. This creates 1000 PLUs. All PLUs is default **Tax1(GST)**, link to **Department 1**.

Initial Clear (Status Clear)

CAUTION: Do not share this information with unauthorized users. Distribute the S Mode key only to those you may want to perform this function.

The initial clear function allows you to exit any register activity and return to a beginning or cleared state. Any transaction that is in progress will be exited and totals for that transaction will not be updated.

Here are some reasons you may want to perform an initial clear:

- The register is in an unknown state, and you wish to exit the current program or transaction without following normal procedures.
- You have performed a function that includes a compulsory activity and you wish to bypass the compulsion.
- An initial clear may be necessary as part of servicing, or troubleshooting.

To Perform an Initial Clear - program restart:

1. Unplug the register.
2. Turn the control lock to the **S** position.
3. Press and hold the **CASH** key on the **default keyboard layout**.
4. While continuing to hold the **CASH** key, plug the register into a power source.
5. The message "***** **INITIAL CLEAR** *****" prints when the initial clear is complete.

Operating Instructions

Function Key Descriptions

Key Descriptions

Key	Description
PAPER FEED	Press to advance then printer paper.
Numeric Keypad: 0-9 and 00	Use the numeric keypad to enter amounts, other numeric values.
CLEAR	Press to clear numeric errors made on keyboard prior to pressing the registration key. Also press to stop the error alarm when incorrect entries are made.
Department Keys	There are eight department keys on the keyboard to register different types of merchandise. Departments may be used to accept open priced entries, or may be programmed to register preset prices
#/NS (#/NO SALE)	Press to open the cash drawer when you have not already started a transaction. Also, may be used to print any number (up to 8 digits) on the printer paper.
X/TIME	Enter a quantity, then press the X/TIME key to enter multiple items. Also use to enter “split pricing” items, such as 1 item at 3 for \$.89.
VOID	Press to void (or erase) the last item entered. You can also void an item previously entered within a transaction by pressing SUBTOTAL , then VOID then re-entering the item you wish to correct.
RETURN	If you wish to return or refund an item, press Return Merchandise, then re-enter any item you wish.
- (MINUS)	Register a negative amount by entering a price, then pressing the - (MINUS) key. For example, you can enter bottle returns or coupons using the - (MINUS) key.
CANCEL	Press to void (or erase) all items entered thus far in any transaction.
C/CONV	Press the Currency Conversion key to convert the sale subtotal into an equivalent value in foreign currency. You must first program foreign currency exchange rates. See “ Currency Conversion ”.
-% , +%	Use the Percent keys to add a percentage surcharge or subtract a

Key	Description
	percentage from an item or the subtotal of the sale. You can enter the amount of the percentage before pressing the -% or +% keys, or you can program a preset percentage if you are consistently using the same percentage. See “ +% and -% Key Programming ” to set a preset percentage.
PLU	Use to register a Price Look Up (PLU).
RA (RECD ACCT)	Use to accept cash into the cash drawer when you are not actually selling merchandise. For example, use the Received on Account key to accept payments for previously sold merchandise or record loans to the cash drawer.
PO (PAID OUT)	Use to track cash paid out for merchandise or to record loans from the cash drawer.
• (Decimal)	Use the Decimal key to enter fractions of percentages. For example to enter a one third off discount, enter 3 3 . 3 3 before pressing the -% key.
CLERK	Use to sign on or sign off a clerk, if you have decided to use a clerk sales tracking system. See “ Clerk Programming ”.
SUB TOTAL	Press to see the subtotal of a sale.
CHARGE (EFTPOS)	Press to total a transaction paid by charge or credit card. (Change name to EFTPOS - EPROM v01.013A)
CHECK	Press to total a transaction paid by check. Also if the check amount is over the amount purchased, enter the amount of the check, then press the CHECK key. The drawer will open and the cash change will be computed.
CASH/TEND	Press to total a transaction paid by cash. Also if the cash amount tendered is over the amount purchased, enter the amount of the tender, then press the CASH/TEND key. The drawer will open and the cash change will be computed.
ADD CHECK	Press when you wish to issue a receipt, but not yet pay for the sale. For example, one person may wish to pay for two guest checks at a restaurant, or one person may pay for two admissions, where separate receipts are required for each person.
TAX	Press to reverse the programmed tax status of a department or plu key. For example, by using the TAX key prior to registering a taxable item, the item will be sold without sales tax added.

Clerk Operations

If you wish to use the clerk system, you must first activate the clerk system by setting system option #16. See “**System Option Programming**”. You can activate the clerk system for stay down or pop-up mode.

- Stay down means that once a clerk is signed on, the same clerk will remain signed on until a different clerk signs on or the original clerk signs off. A stay down clerk system might be used when only one operator uses the register at a time, and a different operator begins when a work shift is changed.
- Pop-up means that the clerk is automatically signed off at the end of each transaction. Therefore, to begin a transaction, you must first sign a clerk on. A pop-up clerk system might be used in a department store, where several clerks might use the register during the same shift, and clerk sales information is required.

Clerk Sign On

To sign On/Off Clerk, need to turn key to **REG** Mode.

- ◆ To sign on, enter the secret code and press the **CLERK** key, or press the **CLERK** key, then enter the secret code and press the **CLERK** key again.

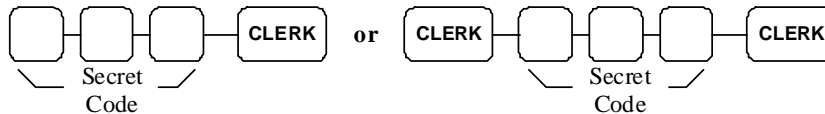

Clerk Sign Off

- ◆ To sign off, enter **0**, press the **CLERK** key.

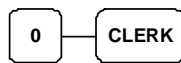

Basic Operations

Registering Items

1. Enter an amount on the ten key pad. *Do not use the decimal key.*

For example, for \$2.99, enter:

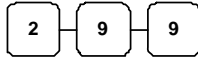

2. Press a department key.
For example, press department 1:



THANK YOU CALL AGAIN		
DEPT.1	T1	\$2.99
ROUND		\$0.01
GST AMOUNT		\$0.27
CASH		\$3.00
16:52	03-01-2006	
000002		00

Repeating an Item

1. To register a second item exactly as the first, press the department key a second time.

For example, press department 1:



THANK YOU CALL AGAIN		
DEPT.1	T1	\$2.99
ROUND		\$0.01
GST AMOUNT		\$0.27
CASH		\$3.00
16:52	03-01-2006	
000003		00

Registering Multiple Items

1. Enter the quantity of items being purchase, press the **X/TIME** key.

For example, enter 4 on the numeric key pad and press the **X/TIME** key:

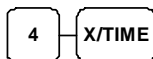

2. Enter an amount on the ten key pad. *Do not use the decimal key.*

For example, for \$1.99, enter:

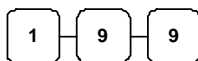

3. Press a department key.
For example, press department 2:



THANK YOU CALL AGAIN		
4 X		\$1.99
DEPT.1	T1	\$7.96
ROUND		-0.01
GST AMOUNT		\$0.72
CASH		\$7.95
16:52	03-01-2006	
000004		00

Department Registrations

As you make department registrations, you can follow your entries by viewing the display. The digits marked “DPT” indicate the department used. The digit marked “RPT” counts items as they are repeated.

Open Department

1. Enter an amount on the ten key pad. *Do not use the decimal key.*

For example, for \$2.99, enter:



2. Press a department key.

For example, press department 1:



THANK YOU CALL AGAIN		
DEPT. 1	T1	\$2.99
ROUND		\$0.01
GST AMOUNT		\$0.27
CASH		\$3.00
16:52	03-01-2006	
000005		00

Preset Price Department

A preset department registers the price that was previously programmed. See “**Department Programming**” to program preset prices.

1. Press a preset department key.
For example, press department 5:



THANK YOU CALL AGAIN		
DEPT. 5	T1	\$1.29
ROUND		\$0.01
GST AMOUNT		\$0.12
CASH		\$1.30
16:52	03-01-2006	
000006		00

Department Repeat Entry

Open or preset price departments may be repeated as many times as necessary by pressing the same department again. (Likewise open or preset PLUs may be repeated by pressing the PLU key again.)

1. Enter an amount on the ten key pad. *Do not use the decimal key.*

For example, for \$2.99, enter:



2. Press a department key.

For example, press department 1:



3. To register a second item exactly as the first, press the department key a second time.

For example, press department 1:



THANK YOU CALL AGAIN		
DEPT.1	T1	\$2.99
DEPT.1	T1	\$2.99
ROUND		\$0.02
GST AMOUNT		\$0.54
CASH		\$6.00
16:52		03-01-2006
000007		00

Multiplication

When several of the same items are to be entered into the same Department, you can use multiplication. You may enter a quantity up to 4 figures (1 to 9999) using the **X/TIME** key. You may multiply open or preset departments.

1. Enter the quantity of items being purchased, press the **X/TIME** key.

For example, enter 4 on the numeric key pad and press the **X/TIME** key:

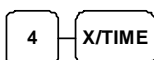

2. Enter an amount on the ten key pad. Do not use the decimal key.

For example, for \$1.99, enter:



3. Press a department key.

For example, press department 1:



THANK YOU CALL AGAIN		
4 X		\$1.99
DEPT.1	T1	\$7.96
ROUND		-0.01
GST AMOUNT		\$0.72
CASH		\$7.95
16:52		03-01-2006
000008		00

Department Multiplication with Decimal Point

If you are selling items by weight, or if you are selling yard goods, you can multiply a fraction of a unit.

1. Enter the quantity purchased with the decimal point, press the **X/TIME** key.

For example, for 3 ¾ kilos of produce, enter:

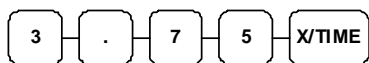

2. Enter an amount on the ten key pad. **Do not use the decimal key.**

For example, if the price is \$.99 per kilo, enter:

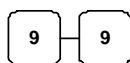

3. Press a department key.

For example, press department 1:



THANK YOU CALL AGAIN		
3.750 X		\$0.99
DEPT.1	T1	\$3.71
ROUND		-0.01
GST AMOUNT		\$0.34
CASH		\$3.70
16:52	03-01-2006	
000009		00

Split Pricing

When items are priced in groups, i.e. 3 for \$1.00, you can enter the quantity purchased and let the register calculate the correct price.

1. Enter the quantity purchased, press the **X/TIME** key.

For example, enter:

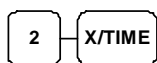

2. Enter the quantity of the group price, press the **X/TIME** key.

For example, if the items are priced 3 for \$1.00, enter:

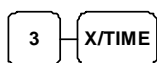

3. Enter an amount on the ten key pad.

For example, if the items are priced 3 for \$1.00, enter:

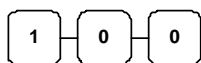

4. Press a department key.

For example, press department 1:



THANK YOU CALL AGAIN		
2/3 X		\$1.00
DEPT.1	T1	\$0.67
ROUND		-0.02
GST AMOUNT		\$0.06
CASH		\$0.65
16:52	03-01-2006	
000010		00

Single Item Department

Single item departments automatically total as a cash sale immediately after registration. Use single item departments for speedy one item sales. For example if you are selling admission tickets, and all ticket sales are one item sales, you can assign open or preset department single item department for ticket sales. After each registration, the drawer will immediately open, and a separate receipt is printed. See **“Department Programming”** to program a single item department.

1. Press a single item preset department key. (or enter a price and press a single item open department key.)

For example, press department **6**:



THANK YOU CALL AGAIN		
DEPT. 6	T1	\$1.29
ROUND		\$0.01
GST AMOUNT		\$0.12
CASH		\$1.30
16:52	03-01-2006	
000011		00

PLU (Price Look Up) Registrations

PLUs must be programmed before operated. See “PLU (Price Look Up) Programming” to program open or preset PLUs.

Open PLU

1. Enter the PLU number, press the **PLU** key.
For example, enter:



2. Enter an amount on the ten key pad. *Do not use the decimal key.*
For example, for \$2.99, enter:

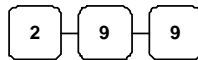

3. Press the **PLU** key again.



THANK YOU CALL AGAIN		
PLU2	T1	\$2.99
ROUND		\$0.01
GST AMOUNT		\$0.27
CASH		\$3.00
16:52	03-01-2006	
000012		00

Preset Price PLU

1. Enter the PLU number, press the **PLU** key.
For example, enter:



THANK YOU CALL AGAIN		
PLU1	T1	\$1.29
ROUND		\$0.01
GST AMOUNT		\$0.12
CASH		\$1.30
16:52	03-01-2006	
000013		00

PLU Repeat Entry

1. Enter the PLU number, press the **PLU** key.
For example, enter:



2. To register a second item exactly as the first, press the PLU key a second time:



THANK YOU CALL AGAIN		
PLU1	T1	\$1.29
PLU1	T1	\$1.29
ROUND		\$0.02
GST AMOUNT		\$0.23
CASH		\$2.60
16:52	03-01-2006	
000014		00

PLU Multiplication

When several of the same items are to be entered into the same PLU, you can use multiplication. You may enter a quantity up to 4 figures (1 to 9999) using the **X/TIME** key. You may multiply open or preset open or preset PLUs.

1. Enter the quantity of items being purchased, press the **X/TIME** key.
For example, enter **4** on the numeric key pad and press the **X/TIME** key:

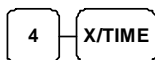

2. Enter the PLU number, press the **PLU** key.

For example, enter:



THANK YOU CALL AGAIN		
4 X		\$1.29
PLU1	T1	\$5.16
ROUND		-0.01
GST AMOUNT		\$0.47
CASH		\$5.15
16:52	03-01-2006	
000015		00

PLU Multiplication with Decimal Point

If you are selling items by weight, or if you are selling yard goods, you can multiply a fraction of a unit.

1. Enter the quantity purchased with the decimal point, press the **X/TIME** key.
For example, for 3 $\frac{3}{4}$ kilos of produce, enter:

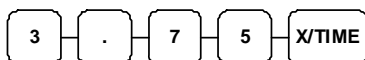

2. Enter the PLU number, press the **PLU** key.
For example, enter:



THANK YOU CALL AGAIN		
3.750 X		\$1.29
PLU1	T1	\$4.84
ROUND		\$0.01
GST AMOUNT		\$0.44
CASH		\$4.85
16:52	03-01-2006	
000016		00

Split Pricing PLU

When items are priced in groups, i.e. 3 for \$1.00, you can enter the quantity purchased and let the register calculate the correct price.

1. Enter the quantity purchased, press the **X/TIME** key.

For example, enter:

2 — **X/TIME**

2. Enter the quantity of the group price, press the **X/TIME** key.

For example, if the items are priced 3 for \$1.00, enter:

3 — **X/TIME**

3. Enter the PLU number, press the **PLU** key.

For example, enter:

1 — **PLU**

THANK YOU CALL AGAIN		
2/3 X		\$1.29
PLU1	T1	\$0.86
ROUND		-0.01
GST AMOUNT		\$0.08
CASH		\$0.85
16:52	03-01-2006	
000017		00

Percent Key (+% and -%) Operations

Use the Percent keys to add a percentage surcharge or subtract a percentage from an item or the subtotal of a sale. You can enter the amount of the percentage before pressing the -% or +% keys, or you can program a preset percentage if you are consistently using the same percentage. Programming determines whether it is possible to enter a percentage when the key is also programmed with a preset percentage. See “+% and -% Key Programming” to set a preset percentage.

Preset Percent on a Department or PLU Item

In this example the -% key is preset with a rate of 10.000.

1. Register the discounted item.
2. Press the -% key:

3. The discount is automatically subtracted.

THANK YOU CALL AGAIN		
DEPT. 2	T1	\$10.00
-%		10.000
		-1.00
ROUND		\$0.00
GST AMOUNT		\$0.82
CASH		\$9.00
16:52	03-01-2006	
000018		00

Enter a Percent on a Department or PLU

You can also operate the -% or +% keys by entering the percentage of the discount or surcharge. If necessary, you can enter the percentage with a decimal key (up to 3 digits, i.e. 99.999%).

1. Register the discounted item.
2. Enter the percentage. If you are entering a fraction of a percent or digit(s) after decimal point, you must use the decimal key.
For example, for 1/3 off enter:



3. Press the -% key:

4. The discount is automatically subtracted.

THANK YOU CALL AGAIN		
DEPT. 2	T1	\$10.00
-%		33.333
		-3.33
ROUND		-0.02
GST AMOUNT		\$0.61
CASH		\$6.65
16:52	03-01-2006	
000019		00

Percent on Sale Total

In this example a surcharge of 15% is applied.

1. Register the items you wish to sell.
2. Press **SUBTOTAL**:

**SUB
TOTAL**

3. Enter the percentage.
For example, for 15% enter:

1 5

4. Press the **+%** key:

+%

5. The surcharge is automatically added.

THANK YOU CALL AGAIN		
DEPT. 2	T1	\$10.00
SUBTOTAL		\$10.00
+%		15.000
		\$1.50
ROUND		\$0.00
GST AMOUNT		\$1.05
CASH		\$11.50
16:52	03-01-2006	
000020		00

Return Merchandise Registrations

If you wish to return or refund an item, press Return Merchandise, then re-enter any item you wish. You can return merchandise as part of a sale, or you can return merchandise as a separate transaction and return cash to the customer.

1. To return an item, press **RETURN**:

RETURN

2. Enter the price of the item you wish to return, then press the department key where it was registered originally.
For example, for \$2.99 on Department 2, enter:

2 9 9 2

3. Total the sale with **CASH/TEND**, **CHECK**, or **CHARGE**.

THANK YOU CALL AGAIN		
RETURN MDSE		
DEPT. 2	T1	\$2.99
ROUND		-0.01
GST AMOUNT		-0.27
CASH		-3.00
16:52	03-01-2006	
000021		00

Voids and Corrections

Void Last Item

This function corrects the last item entered.

1. Register the item you wish to sell.
2. Press the **VOID** key.

VOID

THANK YOU CALL AGAIN		
DEPT. 1	T1	\$2.29
DEPT. 2	T1	\$1.29
VOID		
DEPT. 2	T1	-1.29
ROUND		\$0.01
GST AMOUNT		\$0.21
CASH		\$2.30
16:52	03-01-2006	
000022		00

Void Previous Item

This function allows you to correct an item registered previously in a transaction.

1. Register an item. Then register a second item.
2. To correct the first item, press **CLEAR**, then press **VOID**:



3. Enter the price of the first item, then press the department key where it was registered originally.

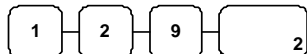

THANK YOU CALL AGAIN		
DEPT. 2	T1	\$1.29
DEPT. 1	T1	\$2.29
VOID		
DEPT. 2	T1	-1.29
ROUND		\$0.01
GST AMOUNT		\$0.21
CASH		\$2.30
16:52		03-01-2006
000023		00

Cancel

The **CANCEL** key allows you to stop any transaction. Anything registered within the transaction before the **CANCEL** key is pressed is automatically corrected. The **CANCEL** key may be inactivated through programming, see "**CANCEL Key Programming**".

1. Register the items you wish to sell.
2. Press the **CANCEL** key.



THANK YOU CALL AGAIN		
DEPT. 1	T1	\$2.29
CANCEL	-----	
-		
16:52		03-01-2006
000024		00

Void Position Operations

You can use the Void control lock position to correct any complete transaction. To correct any transaction:

1. Turn the control lock to the VOID position.
2. Enter the transaction you wish to correct exactly as it was entered originally in the **REG** control lock position. You can enter discounts, voids, returns, tax exemptions or any other function.
3. All totals and counters are corrected as if the original transaction did not take place.

THANK YOU CALL AGAIN		
VOID MODE		
DEPT. 1	T1	-2.29
DEPT. 2	T1	-1.00
SUBTOTAL		-3.29
ROUND		-0.01
GST AMOUNT		-0.30
CASH		-3.30
16:52		03-01-2006
000025		00

- (Minus) Key Registrations

You can register a negative amount by entering a price, then pressing the - (Minus) key. For example, you can enter bottle returns or coupons using the - (Minus) key.

NOTE: You can program the minus key so that tax is charged on the gross amount or on the net amount after the subtraction. See “- (Minus) Key Programming”.

1. Register the items you wish to sell.
2. Enter the amount you wish to subtract from the sale.

For example for a \$.50 coupon, enter:

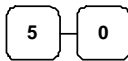

3. Press the - (Minus) key.



THANK YOU CALL AGAIN		
DEPT.1	T1	\$2.29
-		-0.50
ROUND		\$0.01
GST AMOUNT		\$0.21
CASH		\$1.80
16:52	03-01-2006	
000026		00

No Sale Operations

Open Drawer

The #/NS key will open the cash drawer when you have not already started a transaction.

1. Press #/NS:



2. The drawer will open and the receipt will print as in the example on the right.

THANK YOU CALL AGAIN	
OPEN DRAWER	
16:52	03-01-2006
000027	00

Non Add Number

You can also use the #/NS key to print any number (up to 8 digits) on the printer paper. You can enter the number any time during a transaction. For example, if you wish to record a charge account number, enter the number and press the #/NS key before totaling the sale with the **CHARGE** key.

1. Register the items you wish to sell.
2. Enter the number you wish to record.
For example enter:

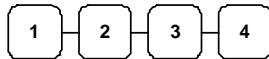

3. Press #/NS:

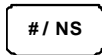

4. Press **CHARGE**:



5. The display will indicate “=” for total, the drawer will open and the receipt will print as in the example on the right.

THANK YOU CALL AGAIN	
DEPT. 1	T1 \$2.99
NON ADD NO.	1234
ROUND	\$0.01
GST AMOUNT	\$0.27
CHARGE	\$3.00
16:52	03-01-2006
000028	00

Received On Account Operations

You can use the Received on Account key to accept cash into the cash drawer when you are not actually selling merchandise. For example, use the Received on Account key to accept payments for previously sold merchandise or record loans to the cash drawer.

1. Enter the amount of cash you are receiving.
For example, enter:

2 0 0 0

2. Press **RA**:

RA

3. The drawer will open and the receipt will print as in the example on the right.

THANK YOU CALL AGAIN	
RECEIVED ON	\$20.00
16:52	03-01-2006
000029	00

Paid Out Operations

You can use the **PAID OUT** key to track cash paid out for merchandise or to record loans from the cash drawer.

1. Enter the amount of cash you are paying.
For example, enter:

2 0 0 0

2. Press **PO**:

PO

3. The drawer will open and the receipt will print as in the example on the right.

THANK YOU CALL AGAIN	
PAID OUT	\$20.00
16:52	03-01-2006
000030	00

Totaling a Cash Sale

1. Register the items you wish to sell.
2. To display and print the subtotal of the sale including tax, press **SUBTOTAL**:

**SUB
TOTAL**

3. To total a cash sale, press **CASH/TEND**:

**CASH/
TEND**

4. The display will indicate “=” for total, the drawer will open and the receipt will print as in the example on the right.

THANK YOU CALL AGAIN		
DEPT. 1	T1	\$2.99
DEPT. 1	T1	\$2.99
4 X		@1.99
DEPT. 2	T1	\$7.96
SUBTOTAL		\$13.94
ROUND		\$0.01
GST AMOUNT		\$1.27
CASH		\$13.95
16:51		03-01-2006
000031		00

Tendering a Cash Sale

1. Register the items you wish to sell.
2. To display and print the subtotal of the sale including tax, press **SUBTOTAL**:

**SUB
TOTAL**

3. Enter the amount tendered by the customer.
For example, for \$20.00 enter:

2 0 0 0

4. Press **CASH/TEND**:

**CASH/
TEND**

5. The display will indicate “C” for change, the drawer will open and the receipt will print as in the example on the right.

THANK YOU CALL AGAIN		
DEPT. 1	T1	\$2.99
DEPT. 1	T1	\$2.99
4 X		@1.99
DEPT. 2	T1	\$7.96
SUBTOTAL		\$13.94
ROUND		\$0.01
GST AMOUNT		\$1.27
TOTAL		\$13.95
CASH		\$20.00
CHANGE		\$6.05
16:52		03-01-2006
000032		00

Tendering a Check Sale

1. Register the items you wish to sell.
2. To display and print the subtotal of the sale including tax, press **SUBTOTAL**:

**SUB
TOTAL**

3. Enter the amount of the check tendered by the customer.

For example, for \$20.00 enter:

2 0 0 0

4. Press **CHECK**:

CHECK

5. The display will indicate "C" for change, the drawer will open and the receipt will print as in the example on the right.

THANK YOU CALL AGAIN		
DEPT.1	T1	\$2.99
DEPT.1	T1	\$2.99
4 X		@1.99
DEPT.2	T1	\$7.96
SUBTOTAL		\$13.94
GST AMOUNT		\$1.27
TOTAL		\$13.94
CHECK		\$20.00
CHANGE		\$6.06
16:52	03-01-2006	
000033		00

Totaling a Charge Sale

1. Register the items you wish to sell.
2. To display and print the subtotal of the sale including tax, press **SUBTOTAL**:

**SUB
TOTAL**

3. Press **CHARGE**:

CHARGE

4. The display will indicate "=" for total, the drawer will open and the receipt will print as in the example on the right.

THANK YOU CALL AGAIN		
DEPT.1	T1	\$2.99
DEPT.1	T1	\$2.99
4 X		@1.99
DEPT.2	T1	\$7.96
SUBTOTAL		\$13.94
GST AMOUNT		\$1.27
CHARGE		\$13.94
16:52	03-01-2006	
000034		00

NOTE: Charge tendering is not allowed.

Totaling and Tendering

Three keys may be used to total and total a sale: **CHECK**, **CHARGE**, **CASH/TEND** key. The **CHECK** and **CASH/TEND** keys can also be used for change calculation.

Subtotaling a Sale

1. Register the items you wish to sell.
2. To display and print the subtotal of the sale including tax, press **SUBTOTAL**:

3. The subtotal will display with “=” indicated in the left digit position of the display.



THANK YOU CALL AGAIN		
DEPT.1	T1	\$2.99
DEPT.1	T1	\$2.99
4 X		\$1.99
DEPT.2	T1	\$7.96
SUBTOTAL		\$13.94
.....		

Totaling a Cash Sale

1. Register the items you wish to sell.
2. To total a cash sale, press **CASH/TEND**:

3. The display will indicate “=” for total, the drawer will open and the receipt will print as in the example on the right.

THANK YOU CALL AGAIN		
DEPT.1	T1	\$2.99
DEPT.1	T1	\$2.99
4 X		\$1.99
DEPT.2	T1	\$7.96
SUBTOTAL		\$13.94
ROUND		\$0.01
GST AMOUNT		\$1.27
CASH		\$13.95
16:52		03-01-2006
000036		00

Tendering a Cash Sale

1. Register the items you wish to sell.
2. Enter the amount tendered by the customer.
For example, for \$20.00 enter:

3. Press **CASH/TEND**:

4. The display will indicate “C” for change, the drawer will open and the receipt will print as in the example on the right.

THANK YOU CALL AGAIN		
DEPT.1	T1	\$2.99
DEPT.1	T1	\$2.99
4 X		\$1.99
DEPT.2	T1	\$7.96
SUBTOTAL		\$13.94
ROUND		\$0.01
GST AMOUNT		\$1.27
TOTAL		\$13.95
CASH		\$20.00
CHANGE		\$6.05
16:52		03-01-2006
000037		00

Tendering a Check Sale

1. Register the items you wish to sell.
2. Enter the amount tendered by the customer.
For example, for \$20.00 enter:



3. Press **CHECK**:



4. The display will indicate "C" for change, the drawer will open and the receipt will print as in the example on the right.

THANK YOU CALL AGAIN		
DEPT.1	T1	\$2.99
DEPT.1	T1	\$2.99
4 X		\$1.99
DEPT.2	T1	\$7.96
SUBTOTAL		\$13.94
GST AMOUNT		\$1.27
TOTAL		\$13.94
CHECK		\$20.00
CHANGE		\$6.05
16:52	03-01-2006	
000038		00

Totaling a Charge Sale

1. Register the items you wish to sell.
2. Press **CHARGE**:



3. The display will indicate "=" for total, the drawer will open and the receipt will print as in the example on the right.

NOTE: Charge tendering is not allowed.

THANK YOU CALL AGAIN		
DEPT.1	T1	\$2.99
DEPT.1	T1	\$2.99
4 X		\$1.99
DEPT.2	T1	\$7.96
SUBTOTAL		\$13.94
GST AMOUNT		\$1.27
CHARGE		\$13.94
16:52	03-01-2006	
000039		00

The descriptor of **CHARGE** key has been modified to "EFTPOS" from EPROM version 01.013A, but the default keyboard layout remains CHARGE.

Check Cashing

Check cashing means exchanging cash for a check. Normally, this function is not allowed. If you wish to allow check cashing, you must set system option #15 to a value of **1**. See “**System Option Programming**”.

1. Enter the amount of the check tendered by the customer.

For example, for \$20.00 enter:

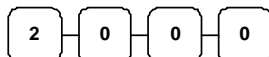

2. Press **CHECK**:



3. The display will indicate “C” for change, the drawer will open and the receipt will print as in the example on the right.

THANK YOU CALL AGAIN	
< CHECK CASHING >	
CHECK	\$20.00
CASH	-20.00
16:52	03-01-2006
000040	00

Split Tender

Split tendering means paying for one sale by different payment methods. For example, a \$20.00 sale could be split so \$10.00 is paid in cash, and the remaining \$10.00 is charged. If necessary, you can make several different payments.

NOTE: If a portion of a sale is to be charged, the charge payment must be entered last.

1. Register the items you wish to sell.
2. Enter the amount of cash tendered by the customer.

For example, enter \$10.00 and press

CASH/TEND:

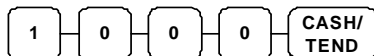

3. The display will indicate “=” and \$10.00, indicating the amount still due. The drawer will not open. Press **CHARGE** to charge the remaining amount:



4. The display will indicate “=” for total, the drawer will open and the receipt will print as in the example on the right.

THANK YOU CALL AGAIN	
DEPT. 2	T1 \$20.00
SUBTOTAL	\$20.00
ROUND	\$0.00
GST AMOUNT	\$1.82
TOTAL	\$20.00
CASH	\$10.00
TOTAL	\$10.00
CHARGE	\$10.00
16:52	03-01-2006
000041	00

Post Tender

Post tendering means computing change after the sale has been totaled and the drawer is open. This feature is useful when a customer changes the amount of the tender or the clerk becomes confused counting change manually. Normally, this function is not allowed. If you wish to allow post tendering, you must set system option #14 to a value of 1. See “System Option Programming”.

1. Register the items you wish to sell.

2. Press **CASH/TEND**:



3. The display will indicate “=” for total, the drawer will open and the receipt will print as in the example on the right.

4. Enter the amount of the tender, Press **CASH/TEND**:

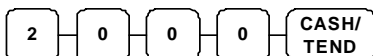

5. The display will indicate “=” for change and display \$17.88 change due.

THANK YOU CALL AGAIN		
DEPT.1	T1	\$2.00
SUBTOTAL		\$2.00
ROUND		\$0.00
GST AMOUNT		\$0.18
CASH		\$2.00
16:52	03-01-2006	
000042		00

Currency Conversion

If you normally accept currency from a neighboring nation, you can program the *SAM4s ER-260/265* to convert the subtotal of a sale to the equivalent cost in the foreign currency. To do this, you need to program the conversion factor. For example, if the Amount (home currency) is worth 1.3720 Canadian dollars (foreign currency), the conversion factor is 1.3720. See “**Programming Currency Exchange Rates**” to set a conversion rate.

1. Register the items you wish to sell.
2. Press **SUBTOTAL** to display the amount due in your home currency:

**SUB
TOTAL**

3. To convert the amount due to an equivalent value in foreign currency, press **C/CONV**:

C/CONV

4. Enter the amount of the foreign currency tender, Press **CASH/TEND**:

1 0 0 0 **CASH/
TEND**

5. The display will indicate “C” for change and display \$5.17 change due. **The change due is computed in home currency!**

THANK YOU CALL AGAIN		
DEPT. 1	T1	\$2.00
SUBTOTAL		\$2.00
ROUND		\$0.00
GST AMOUNT		\$0.18
TOTAL		\$2.00
FOREIGN AMT.	@10.00	
CHANGE RATE	#1.3720	
HOME AMT.		\$7.29
CHANGE		\$5.29
16:52	03-01-2006	
000043		00

Add Check

Use the **ADD CHECK** key when you wish to issue a receipt, but not yet pay for the sale. For example, one person may wish to pay for two guest checks at a restaurant, or one person may pay for two admissions, where separate receipts are required for each person.

1. Register the items you wish to sell on the first receipt.
2. Press **ADD CHECK** to issue a receipt for the items:

ADD
CHECK
3. Register the items you wish to sell on the next receipt, press **ADD CHECK** to issue a receipt for the items:

ADD
CHECK
4. Press **SUBTOTAL** to display the amount due for both of the receipts:

SUB
TOTAL
5. Total or tender the sale with **CASH/TEND**, **CHECK** or **CHARGE**

THANK YOU CALL AGAIN		
DEPT.1	T1	\$2.00
ADD CHECK		\$2.00
GST AMOUNT		\$0.18
16:52	03-01-2006	
000044		00
THANK YOU CALL AGAIN		
DEPT.2	T1	\$5.00
ADD CHECK		\$5.00
GST AMOUNT		\$0.45
16:52	03-01-2006	
000045		00
THANK YOU CALL AGAIN		
SUBTOTAL		\$7.00
ROUND		\$0.00
GST AMOUNT		\$0.64
CASH		\$7.00
16:52	03-01-2006	
000046		00

Receipt On/Off and Receipt on Request

When a receipt is not normally issued, you can turn the receipt function on or off.

If the receipt is off, you can still issue a receipt after the sale has been completed. Normally, this function is not allowed. If you wish to allow after sale receipts, you must set system option #17 to a value of 1. See “**System Option Programming**”.

To Turn the Receipt Off

- ◆ With the control lock in the **REG** position, press **PO**:



To Turn the Receipt On

- ◆ With the control lock in the **REG** position, press **PO** again:



Printing a Receipt after the Sale

- ◆ After the sale has been totaled, but before the next transaction is started, press **CASH/TEND**:



NOTE: Because receipt memory is limited, when a sale has **more than 30 items or more than 3 tenders**, the receipt after sale **can not** print all items. A row of dots is printed indicating the receipt is incomplete.

For more than **30 items**, the ‘row of dots’ is located **after the 30th item**;
For more than 3 tenders, the ‘row of dots’ is located **before the last tender**.

Calculator Operation

You can use a calculator program in the REG or VOID mode.

1. Turn the control lock to the **REG or VOID** position.
2. Enter 100 on the numeric keypad and press the **SUB TOTAL** key.
3. Enter a first number for calculation on the numeric keypad.
4. Choose one out of below operators.

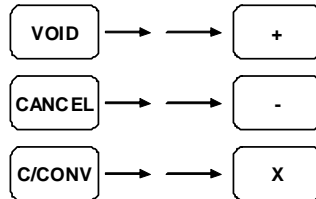

5. Enter a second number for calculation on the numeric keypad.
6. Press the **CASH/TEND** key to finish.

X/Z Mode Reporting

Report Summary

There are two basic types of reports: "X", or read-only and "Z", or read & reset to zero. Some reports are available in both types.

The following table summarizes the reports available on the *SAM4s ER-260/265*:

Running a Report

1. Find the report you wish to run from the table on the previous page.
2. Turn the control lock to the **X** or the **Z** position.
3. Press the appropriate key for the report you wish to run.

Report Table

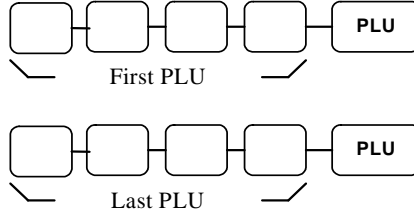
Report	Control Lock Position	Key
Financial	X or Z	CASH/ TEND
Period-to-Date Financial	X or Z	CHARGE
Hourly Sales	X or Z	X/TIME
All PLU	X or Z	PLU
Clerk	X or Z	CLERK
String Report (Financial, PLU, Time and Clerk reports in sequence)	Z	SUB TOTAL
From/To PLU	X	
Cash in Drawer	X	SUB TOTAL
Check in Drawer	X	CHECK

Electronic Journal (EJ) Table

PRINT ALL EJ	X	3 0 0	CASH/ TEND
PRINT EJ CASH	X	3 0 1	CASH/ TEND
PRINT EJ CHECK	X	3 0 2	CASH/ TEND
PRINT EJ CHARGE	X	3 0 3	CASH/ TEND
PRINT EJ %	X	3 0 4	CASH/ TEND
PRINT EJ RA/PO	X	3 0 5	CASH/ TEND
PRINT EJ RETURN	X	3 0 6	CASH/ TEND
PRINT EJ EC/VOID	X	3 0 7	CASH/ TEND
PRINT EJ NO SALE	X	3 0 8	CASH/ TEND
PRINT EJ CANCEL	X	3 0 9	CASH/ TEND
PRINT EJ BY CLERK	X	<input type="text"/> <input type="text"/> <input type="text"/> 401 ~ 410	CASH/ TEND
PRINT EJ RESET	Z	3 9 9	CASH/ TEND

Cash-In-Drawer Declaration

Cash-In-Drawer Declaration is an optional feature that forces you to count the drawer and declare the drawer count before a report can be run. By forcing the operator to declare, without knowledge of the expected drawer totals, you are assured that all cash will be deposited. System option #8 must be set to a value of **1** to enforce cash declaration. See “**System Option Programming**” for detail.

Declaring Cash

1. Turn the control lock to the **X** position.
2. Enter the amount of the cash counted, press the **SUBTOTAL** key:

3. The printer will print the declared amount, the cash-in-drawer total from the cash register and compute the difference
4. Proceed to run the report you wish to print.

THANK YOU CALL AGAIN	
INPUT AMOUNT	\$98.79
CASH IN DRAWER	\$92.29
DIFFERENCE	\$67.65
16:52	03-01-2006
000047	00

NOTE: You must run a report after declaring cash before registering any new transactions.

Setting Receipt/Journal Status

The printer can be set to generate customer receipts, or print a sales journal. In the receipt mode, the printer will print the logo and feed the paper a sufficient length so that a receipt can be torn off. In the journal mode, there is no additional paper feeding between transactions. The default state of this program is the RECEIPT status.

To change the printer status from receipt to journal, or from journal to receipt:

1. Turn the control lock to the **X** position.
2. Enter 9999 on the numeric keypad and press the **PO** key.



Service Mode Programming

Memory Allocation Scan

Program 60 - Memory Allocation Scan

1. Turn the control lock to the S position.
2. To view Memory Allocation, enter **60**, and then press the **SBTL** key.

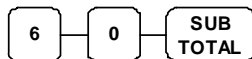

3. Press CASH key.



EPROM Information

Program 50 - EPROM Information

1. Turn the control lock to the S position.
2. To Scan EPROM Information, enter 50, and then press the **SUBTOTAL** key.

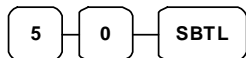

PC Online Mode

In *ER-260/265 Series*, There are easy to enter PC Online Mode.

1. Turn the control lock to the S position
2. Press **RA** key.



Program Mode Programming

Default Programming

- All keyboard Departments are taxable and preset, without entry limits by default status programming of "**310**" (**EPROM v01.014A and later**); are taxable and open, without entry limits by default status programming of "**10**" (**EPROM v01.013A and earlier**).
- All PLUs are taxable and preset, without entry limits by default status programming of "**110**".
- All system options are set to **0** in default programming, unless otherwise noted. Change only the options that will deviate from default programming. There is no need to re-enter an option status of **0**, since **0** is its original setting.
- All programming (unless otherwise noted) is done with the control lock in the **P** position. Each section details a specific area of register programming.
- The Default program is set to **10.000% VAT on Tax 1** and the description is set to **GST** already.

Basic Programming

This section covers the basic programming necessary to get your cash register running quickly. See “Advanced Programming” for if you wish to program options that are not included in this section.

Setting the Date

The date sequence is Day- Month -Year.

1. Turn the control lock to the **PGM** position.
2. Enter the date in the format you have selected and press the **X/TIME** key.
3. Press **CASH/TEND**.

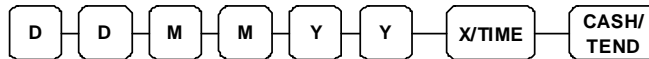

Date Setting Example

If the date is January 3, 2006, enter:

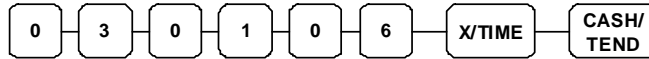

The date you have entered will display and print on the printer:

THANK YOU CALL AGAIN	
	03-01-2006
	PROGRAM TERMINATE
16:36	03-01-2006
000048	00

Setting the Time

1. Turn the control lock to the **PGM** position.
2. Enter the hour and minute in military time (24 hour time) and press the **X/TIME** key.
3. Press **CASH/TEND**.

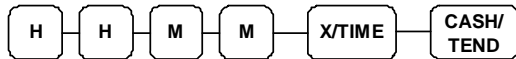

Time Setting Example

If the time is 3:25 PM, enter:

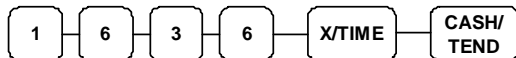

The time you have entered will display and print on the printer:

THANK YOU CALL AGAIN	
16:36	
	PROGRAM TERMINATE
16:36	03-01-2006
000049	00

Programming Tax

You can be programmed by entering a tax percentage rate

Programming a Tax Rate Percentage

1. Turn the control lock to the **PGM** position.
2. Enter the rate, with a decimal. 0.000-99.999. It is not necessary to enter proceeding zeros. For example, for 6%, enter 06.000 or 6.000.)
3. Enter **10**.
4. Enter:

1	to set GST rate
2	to set tax 2 rate
3	to set tax 3 rate
4	to set tax 4 rate

5. Press the **TAX** key.
6. Press the **CASH/TEND** key to end programming.
7. See tax rate program examples.

Tax Rate Programming Flowchart

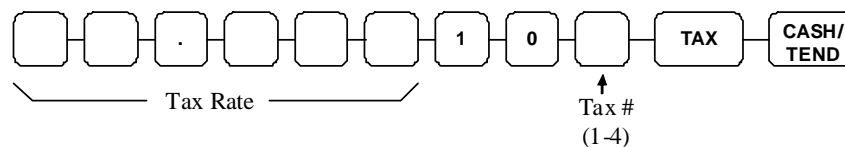

Please Note: After programming the tax rate, you must program your department or departments taxable to calculate tax. See “department programming” steps.

Tax Rate Programming Example

If tax 1 is 10 percent GST, enter:

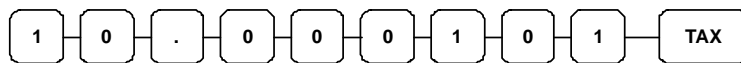

Press the **CASH/TEND** key to end programming.



The rates you have entered will display and print on the printer:

THANK YOU CALL AGAIN	
GST STATUS	10
GST RATE	10.000
PROGRAM TERMINATE	
16:36	03-01-2006
000050	00

Department Programming

Programming Department Status

There are two parts to department programming. Department status is set here. Depending on whether you select open or preset department status in this section, you can also program either the open department entry limit or the preset department price. See “**Programming Department Entry Limit or Price**”.

Use this section to program the following status options:

- Set negative departments that subtract from the sale, rather than normal positive departments which add to the sale.
- Enforce the entry of a non-adding number before the department entry. See “**Non Add Number**” for operation sequences.
- Disable the departments, so that entries are not allowed.
- Choose Open or Preset departments. Open departments accept amount entries. Use open departments to enter different priced items into the same category. Preset departments automatically register a preprogrammed price when the department key is pressed. Use preset departments to register an individual item quickly and accurately. For example, cigarette packs or food items can be assigned to departments as presets.

When you select preset departments, you can also decide if the department can also accept open entries. This option is referred to as “**preset override**”.

- Set single item departments which automatically total as a cash sale immediately after the department entry. Single item departments are used to speed up one item sales.
- Select a tax status to determine whether sales tax is automatically added.
- Department status is preset **0 3 1 0** on EPROM v1.014A and later; **0 0 1 0** on EPROM v1.013A and Earlier.

Unless otherwise programmed, departments are positive, open, not taxable, not single item departments, and accept unlimited amounts (up to **7 digit** entry). Therefore, it is not necessary to program departments you wish to be open, positive, non-taxable, not single item, with no entry limit.

Programming Department Status

1. Turn the control lock to the **PGM** position.
2. Enter **1 0 0 SBT**L for department programming.
3. Decide if you want a negative, enforced non-add entry, or disabled department. If you do not want any of these department options, enter **0**. If you wish to select any of these options, complete the table below by adding the status digits for each option. Enter the resulting digit.

Department is Negative	Yes = 1 No = 0		+	0
Enforce Non-Add Entry	Yes = 2 No = 0		+	0
Department is Disabled	Yes = 4 No = 0		+	0
			=	0

4. Decide if you want a preset or single item department. If you do not want any of these department options, enter **0**. If you wish to select any of these options, complete the table below by adding the status digits for each option. Enter the resulting digit.

Department is Preset	Yes = 1 No = 0		+	1
Allow Preset Override	Yes = 2 No = 0		+	2
Department is Single Item	Yes = 4 No = 0		+	0
			=	3

5. Select tax status by choosing a status from tax.tatus table below.

No Tax	0
Taxable by Rate 1	1
Taxable by Rate 2	2
Taxable by Rate 3	3
Taxable by Rate 4	4

6. For the use the KP.

Send KP?	Yes = 1 No = 0		+	0
			=	0

7. Press the **X/TIME** key.
8. Press a department key which the setting for.
9. Repeat steps 3 to 8 for each department you wish to program.
10. Press the **CASH/TEND** key to end programming.

Department Status Programming Flowchart

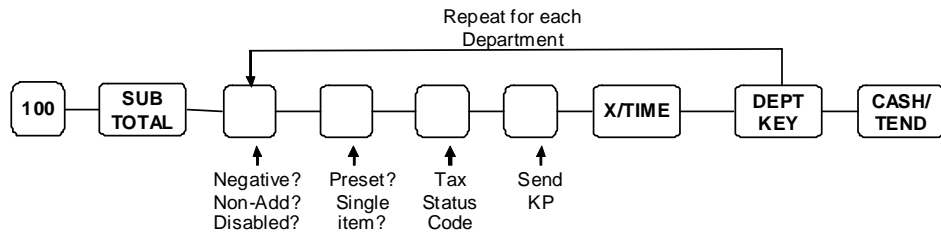

Department Status Programming Examples

For example, set:

- department 1 open, taxable by rate 1
- department 4 preset, taxable by rate 2
- department 9 negative, preset, taxable by rate 3

To set Department 1, enter:

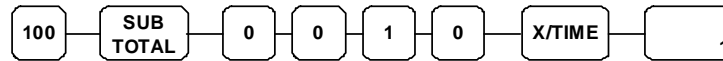

To set Department 4, enter:

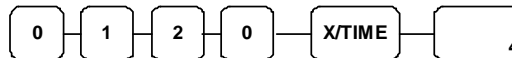

To set Department 9, enter:

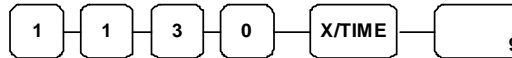

Press the **CASH/TEND** key to end programming.



The status you have entered will display and print on the printer:

THANK YOU CALL AGAIN		
DEPT.1	T1	10
DEPT.4	T1	120
DEPT.9	T1	1130
PROGRAM TERMINATE		
16:36		03-01-2006
000051		00

Programming Department Entry Limit or Price

NOTE: Open departments are automatically assigned a 7 digit entry limit. You do not need to program this section for open departments, unless you wish to set a different limit.

If you are programming a open department:

- You can limit errors by setting the maximum amount that may be entered into a department.

If you are programming a preset department:

- You can set the preset price. The price you program here is the amount that is automatically registered when the department key is pressed.

Programming a Department Entry Limit or Price

1. Turn the control lock to the **PGM** position.
2. If the department is preset, enter the preset price, up to seven digits (01 to 1234567). (It is not necessary to enter proceeding zeros. For example enter \$1.00 as 100.)

OR,

If the department is open, enter the entry limit you wish to set.

3. Press the department key you wish to program.
4. Repeat step 2 and 3 for each department you wish to set.
5. Press the **CASH/TEND** key to end programming.

Department Entry Limit or Price Programming Flowchart

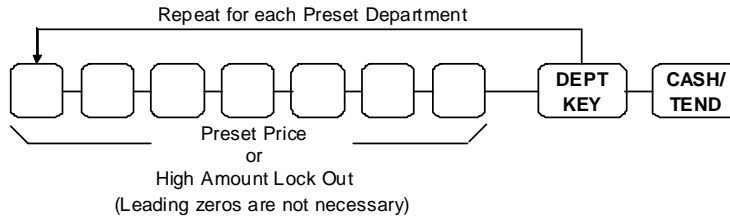

Department Entry Limit or Price Programming Examples

For example, set:

- department 1 open, with a entry limit of \$50.00
- department 4 preset for \$2.50
- department 9 preset for \$0.99

To set Department 1, enter:

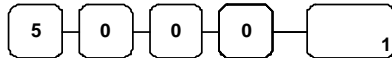

To set Department 3, enter:

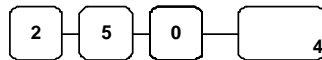

To set Department 9, enter:

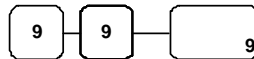

Press the CASH/TEND key to end programming.



The tax status you have entered will display and print on the printer:

THANK YOU CALL AGAIN		
DEPT.1	T1	\$50.00
DEPT.4	T1	\$2.50
DEPT.9	T1	\$0.99
PROGRAM TERMINATE		
16:36		03-01-2006
000052		00

PLU (Price Look Up) Programming

The *SAM4s ER-260/265* offers 1000 PLUs (Price Look Ups) as a standard feature. Like departments PLUs (Price Look Ups) may be *open* or *preset*.

- Preset PLUs are used to register preset items. The most significant difference between a preset department and a preset PLU is the method of registration. While preset departments are registered by simply pressing the department key, preset PLUs are registered by entering the PLU number and pressing the PLU key.
- There are many possible uses for preset PLUs. Since there are many more PLUs than departments, you may use PLUs when you wish to accurately price and count a larger group of items. Possible uses include: menu items in a restaurant or items (such as cigarettes) that you wish to inventory.
- Use open PLUs when you wish to enter different priced items into a larger number of categories.

Programming PLU Status

There are two parts to PLU programming. PLU status is set here. Depending on whether you select open or preset PLU status in this section, you can also program either the open PLU entry limit or the preset PLU price. See “**Programming PLU Entry Limit or Price**”.

Use this section to program the following status options:

- Set negative PLUs that subtract from the sale, rather than normal positive PLUs which add to the sale.
- Enforce the entry of a non-adding number before the PLU entry. See “**Non Add Number**” for operation sequences.
- Disable the PLUs, so that entries are not allowed.
- Choose Open or Preset PLUs.
- Set single item PLUs which automatically total as a cash sale immediately after the department entry. Single item departments are used to speed up one item sales.
- Select a tax status to determine whether sales tax is automatically added.
- PLU status id preset to **0 1 1 0**

Programming PLU Status

1. Turn the control lock to the **PGM** position.
2. Enter the number of the PLU you wish to program (1-1000), press the **PLU** key.
3. Decide if you want a negative, enforced non-add entry, or disabled PLU. If you do not want any of these options, enter **0**. If you wish to select any of these options, complete the table below by adding the status digits for each option. Enter the resulting digit.

PLU is Negative	Yes = 1 No = 0		+	0
Enforce Non-Add Entry	Yes = 2 No = 0		+	0
PLU is Disabled	Yes = 4 No = 0		+	0
			=	0

4. Decide if you want a preset or single item PLU. If you do not want any of these options, enter **0**. If you wish to select any of these options, complete the table below by adding the status digits for each option. Enter the resulting digit.

PLU is Preset	Yes = 1 No = 0		+	1
PLU is Single Item	Yes = 2 No = 0		+	0
			=	1

5. Select tax status by choosing a status from tax.tatus table below.

No Tax	0
Taxable by GST	1
Taxable by Rate 2	2
Taxable by Rate 3	3
Taxable by Rate 4	4

6. For the use the KP.

Send KP?	Yes = 1 No = 0		+	0
			=	0

7. Press the department key that you want this PLUs' sales added to.
8. Repeat steps 2 to 7 for each PLU you wish to program.
9. Press the **CASH/TEND** key to end programming.

PLU Status Programming Flowchart

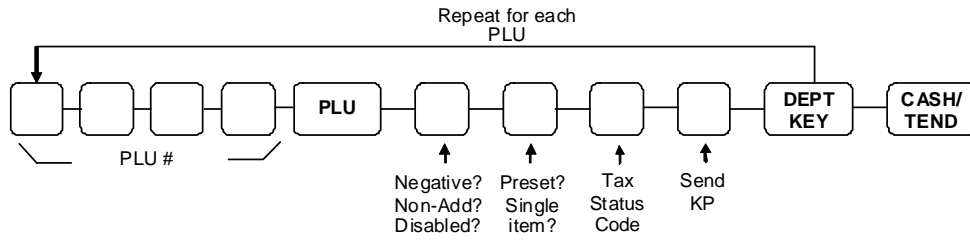

PLU Status Programming Examples

For example, set:

- PLU #1 preset, not single item, taxable by rate 1, with sales reported to department 2.
- PLU #30 preset, single item, taxable by rate 2, with sales reported to department 4.
- PLU #6 open, not single item, non-taxable, with sales reported to department 9.

To set PLU 1, enter:

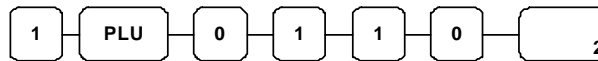

To set PLU 30, enter:



To set PLU 6, enter:

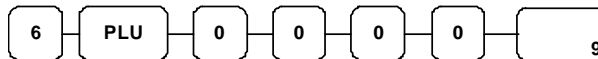

Press the **CASH/TEND** key to end programming.



The status you have entered will display and print on the printer:

THANK YOU CALL AGAIN		
PLU1	T1	110
DEPT.2		
PLU30	T2	320
DEPT.4		
PLU6		0
DEPT.9		
PROGRAM TERMINATE		
16:36		03-01-2006
000053		00

Programming PLU Entry Limit or Price

NOTE: Open PLUs are automatically assigned a 7 digit entry limit. You do not need to program this section for open PLUs, unless you wish to set a different limit.

If you are programming a open PLU:

- You can limit errors by setting the maximum amount that may be entered into a PLU.

If you are programming a preset PLU:

- You can set the preset price. The price you program here is the amount that is automatically registered when the PLU is entered.

Programming a PLU Entry Limit or Price

1. Turn the control lock to the **PGM** position.
2. Enter the number of the PLU you wish to program (1-1000),
3. Press the **PLU** key.
4. If the PLU is preset, enter the preset price, up to seven digits (01 to 1234567). (It is not necessary to enter proceeding zeros. For example enter \$1.00 as 100.)

OR

If the PLU is open, enter the highest amount that may be entered into the PLU.

5. Press the **X/TIME** key.
6. Repeat from step 2 to 5 for each PLU you wish to program.
7. Press the **CASH/TEND** key to end programming.

PLU Entry Limit or Price Programming Flowchart

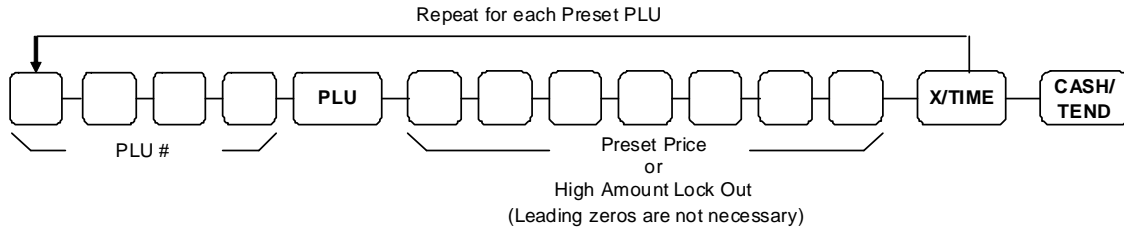

PLU Entry Limit or Price Programming Examples

For example, set:

- PLU 1 with a preset price of \$1.99
- PLU 30 with a preset price of \$10.00
- PLU 6 with a entry limit of \$5.00

To set PLU 1, enter:



To set PLU 30, enter:



To set PLU 6, enter:

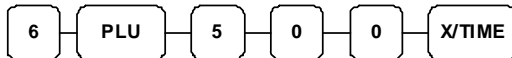

Press the CASH/TEND key to end programming.



The tax status you have entered will display and print on the printer:

THANK YOU CALL AGAIN		
PLU1	T1	@1.99
PLU30	T1	@10.00
PLU6	T1	@5.00
PROGRAM TERMINATE		
16:36		03-01-2006
000054		00

System Option Programming

Twenty system options are provided so that you can configure the *SAM4s ER-260/265* to your exact requirements. Refer to the “**System Option Table**” to review the system options. Read each option carefully to determine if you wish to make any changes.

NOTE: Because after clearing memory all options settings are automatically set to 0, and because your most likely option selections require a status setting of 0, you do not need to program this section unless you wish to change the default status.

Programming a System Option:

1. Turn the control lock to the **PGM** position.
2. Enter the option number of the system option you wish to change.
3. Press the **RA** key.
4. Enter the number representing the status you have selected.
5. Press the **PO** key.
6. Repeat step 2 to 5 for each system option you wish to change.
7. Press the **CASH/TEND** key to end programming.

System Option Flowchart

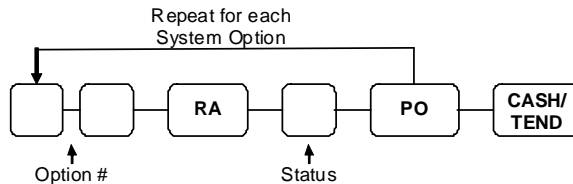

System Option Programming Examples

Set the following options

- Option 15: Allow check cashing.
- Option 20: Enforce cash or check tender at totaling.

To set option 16:



To set option 20:



Press the **CASH/TEND** key to end programming.



System Option Table

NOTE: Bold font is the default settings. In other words, the Bold font setting indicates the way the register is automatically set up after.

Option No.	SYSTEM OPTION	STATUS	
1	Print the grand total on X,Z report.	YES = 0 NO = 1	
2	Print the gross total on X,Z report.	YES = 0 NO = 1	
3	Reset the consecutive number counter after a Z report.	NO = 0 YES = 1	
4	Reset the Z counter after Z report.	NO = 0 YES = 1	
5	Skip totals with zero value on X,Z report.	YES = 0 NO = 1	
6	Reset the grand total after a Z report.	NO = 0 YES = 1	
7	Print the subtotal when pressed.	YES = 0 NO = 1	
8	Cash must be declared before X,Z report.	NO = 0 YES = 1	
9	Allow X reports	YES = 0 NO = 1	
10	Decimal point position	0 = none	
		1 = 1 place	
		2 = 2 places	
		3 = 3 places	
11	Select a method for tax printing:		
	Print Taxable Totals.	Print tax amounts separately	0
		Print only total of all taxes	1
		Do not print tax amounts	2
	Do not print Taxable Total.	Print tax amounts	3
		Print only total of all taxes	4
Do not print tax amounts		5	
12	Rounding method for percentage key and tax.	Round up at 0.50	0
		Always Round up	1
		Always Round down	2
13	Rounding method for decimal multiplication and split pricing.	Round up at 0.50	0
		Always Round up	1
		Always Round down	2
14	Allow Post Tender.	NO = 0 YES = 1	
15	Allow Check Cashing.	NO = 0 YES = 1	

Option No.	SYSTEM OPTION	STATUS	
16	Select clerk option:	Inactive	0
		Stay	1
		Pop Up	2
17	Allow receipt after sale.	NO = 0 YES = 1	
18	Print Currency Symbol	\$	
19	Enforce cash or check tender at totaling.	NO = 0 YES = 1	
20	Date sequence	MM-DD-YY	0
		DD-MM-YY	1
		YY-MM-DD	2
21	Select drawer compulsory	NO = 0 YES = 1	
22	Use spool	NO = 0 YES = 1	
23	Electronic Journal	Disable.	0
		Enable Print from Oldest.	1
		Enable Print from Newest	2
24	Prompt operator when Electronic Journal is full	NO = 0 YES = 1	SUM
	Stop operations when Electronic journal is full	NO = 0 YES = 2	
	Send reset report to Electronic journal	NO = 0 YES = 4	
25	Paper End Sensor	YES = 0 NO = 1	
26	Print small font EJ REPORT for journal printer	Disable	0
		Enable	1
27	Overlay discriptor	NO = 0 YES = 1	
28	Print in high density * Note : 1. This option lowers the printing speed. 2. This option can affect to the life cycle of printer head.	NO = 0 YES = 1	
29	Pre Print graphic logo on receipt?	NO = 0 YES = 1	
30	Use Kitchecn Printer (ELLIX 20)	NO = 0 YES = 1	
31	Ending feeding line on KP (0-9)	4	
32	Rounding	Disable	0
		Australia	1
		New Zealand	2

Advanced Tax Programming

Use the instructions in this chapter only if you wish to determine tax program entries yourself. See “Programming Tax” to enter a simple tax rate.

Important Note: After you have entered your tax program, test for accuracy by entering several transactions of different dollar amounts. Carefully check to make sure the tax charged by the cash register matches the tax on the printed tax chart for your area. As a merchant, you are responsible for accurate tax collection. If the cash register is not calculating tax accurately, contact your local SAM4s Dealer for assistance.

Tax Rate Programming

You can program up to three separate taxes on the SAM4s ER-260. Set tax rate(s) here.

Programming Tax Rates and Status

1. Turn the control lock to the PGM position.
2. If the tax is a percentage rate, enter it with a decimal (0.000-99.999). It is not necessary to enter proceeding zeros. For example, for 6%, enter 06.000 or 6000.
3. For the type of tax, enter:

0	if the tax is a percentage added to the sale (normal add on tax)
1	if the tax is a percentage value added tax (VAT; calculated as part of the sale)

- 4.

0	RESERVED
---	----------

5. Enter:

1	to set GST
2	to set tax rate 2
3	to set tax rate 3
4	to set tax rate 4

6. Press the TAX key.
7. Press the CASH/TEND key to end programming.

Tax Rate Programming Flowchart

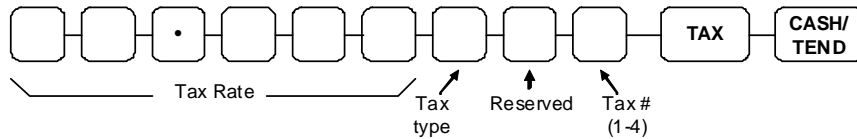

Tax Rate Examples

If tax 1 is 6 percent, enter:

6 . 0 0 0 0 0 1 TAX

If tax 3 is 8 percent, enter:

8 . 0 0 0 2 0 3 TAX

Press the CASH/TEND key to end programming.

CASH/
TEND

The rates you have entered will display and print on the printer:

THANK YOU CALL AGAIN		
TAX1 STATUS		00
TAX1 RATE		6.000
TAX3 STSTUS		03
TAX3 RATE		8.000
PROGRAM TERMINATE		
16:36		03-01-2006
000055		00

+% and -% Key Programming

There are two percentage keys on the keyboard: +% and -%. The +% key applies a surcharge. The -% key applies a discount. Without any further programming, you can apply a discount or surcharge to an individual item or to the subtotal of a sale by entering a percentage and pressing the +% or -% key. This program allows you to:

- decide to calculate any taxes *before* or *after* the percentage is applied
- set a preset percentage for the +% or -% key
- if a preset percentage is set, decide if you wish to also allow a percentage to be entered
- inactivate the key

Programming the +% or -% Key

1. Turn the control lock to the **PGM** position.
2. Enter the percentage rate you wish to preset, or **0** if you only wish to enter the percentage. Press the +% or -% key, depending on which key you are programming. Be sure **not to enter the decimal point** while setting a rate, i.e. enter **3 3 3 3 3** as 33 1/3 % and enter **5 0 0 0 0** as 50%.
3. To decide if the rate calculated before or after the discount/surcharge.

0	Calculate Tax before the discount/surcharge?
1	Calculate Tax after the discount/surcharge?

4. Enter:

0	If you wish to allow the operator to also enter a percentage (override).
1	If you do not wish to allow the operator to also enter a percentage (override).
2	If you wish the key to be inactive.

5. Press the CASH/TEND key to end programming.

+% or -% Key Programming Flowchart

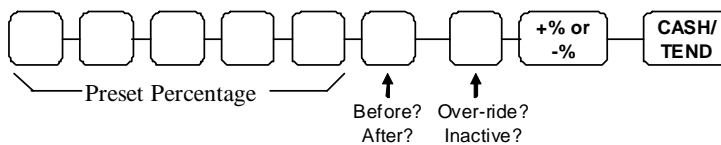

+% or -% Key Programming Example

Set the -% (discount) Key preset for 50% and so that tax is calculated after the discount is applied and override is allowed. Enter:

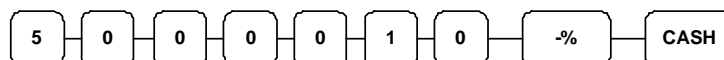

- (Minus) Key Programming

The - (Minus) key is used to enter the amount of a coupon that is subtracted from the sale.

- The - (Minus) key can be programmed to be taxable or non-taxable. In other words, when you are subtracting a coupon, you can calculate sales tax on the net or the gross cost of the item. If the - (Minus) key is taxable, you will calculate sales tax on the net cost of the item. If the - (Minus) key is non-taxable, you will calculate sales tax on the gross cost of the item.
- You can also program limit errors by setting the maximum amount that may be entered into the - (Minus) key. For example, setting a 3 digit limit means the maximum you can enter is \$9.99. This is referred to as the High Digit Lock Out, or HDLO.

Programming the - (Minus) Key

- Turn the control lock to the PGM position.
- Enter the High Digit Lock Out (entry limit) digit from the table below. (Enter 0 for no limit.)

HDLO	Limits	HDLO	Limits
1	.01 - .09	4	.01 - 99.99
2	.01 - .99	5	.01 - 999.99
3	.01 - 9.99	6	.01 - 9999.99
0	.01 - 99999.99		

- To decide if the rate calculated before or after the Minus (-) key.

0	Calculate Rate before the Minus (-) key?
1	Calculate Rate after the Minus (-) key?

- Enter:

0	for active minus key
1	for inactive minus key

- Press the - (Minus) key.
- Press the CASH/TEND key to end programming.

Minus (-) Key Programming Flowchart

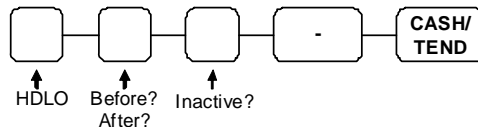

Minus (-) Key Programming Example

Set the Minus (-) key with a three digit HDLO (\$9.99) and so that tax is calculated after the Minus (-) key amount is entered. (In other words, tax is calculated on the net cost of the item.) Enter:

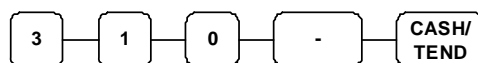

CANCEL Key Programming

The **CANCEL** key can be made inactive. Normally the key is active, however, you may wish to inactivate it for security reasons.

Programming the CANCEL Key

1. Enter:
 - 0 to activate the **CANCEL** key
 - 1 to inactivate the **CANCEL** key
2. Press the **CANCEL** key.
3. Press the **CASH/TEND** key to end programming.

Cancel Key Programming Flowchart

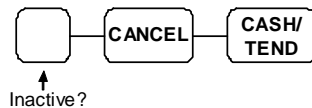

Cancel Key Programming Example

To inactivate the **CANCEL** key, enter:



Currency Conversion Programming

If you normally accept currency from a neighboring nation, you can program the *SAM4s ER-260/265* to convert the subtotal of a sale to the equivalent cost in the foreign currency. To do this, you need to program the conversion factor. For example, if the Amount (home currency) is worth 1.3720 Canadian dollars (foreign currency), the conversion factor is 1.3720.

NOTE: Foreign currency exchange rates may be stated as “foreign currency in dollars”, or “dollars in foreign currency”. Use the rate stated in “dollars in foreign currency” when you are programming this section.

Programming Currency Exchange Rates

1. Turn the control lock to the **PGM** position.
2. Enter the exchange rate of up to 5 digits (do not enter the decimal point).
3. Enter a number from 0 to 4 to indicate the decimal position.
4. Press the **C/CONV** key.
5. Press the **CASH/TEND** key to end programming.

Currency Exchange Rate Programming Flowchart

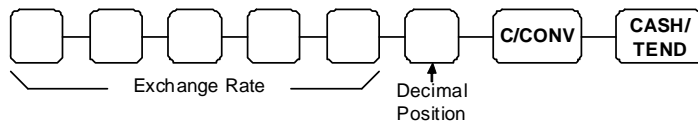

Currency Exchange Rate Programming Example

The Amount (home currency) is worth 1.3720 Canadian dollars (foreign currency).

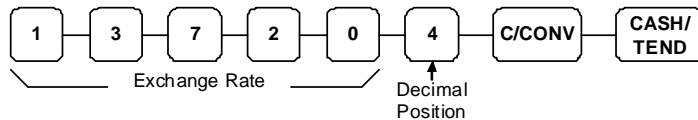

Clerk Programming

If you wish to use the clerk system, you must first activate the clerk system by setting system option #16. See “**System Option Programming**”. You can activate the clerk system for with a stay down or pop-up mode.

- Stay down means that once a clerk is signed on, the same clerk will remain signed on until a different clerk signs on or the original clerk signs off. A stay down clerk system might be used when only one operator uses the register at a time, and a different operator begins when a work shift is changed.
- Pop-up means that the clerk is automatically signed off at the end of each transaction. Therefore, to begin a transaction, you must first sign a clerk on. A pop-up clerk system might be used in a department store, where several clerks might use the register during the same shift, and clerk sales information is required.

With the clerk system activated, you can operate up to 10 clerks. The clerk registering a transaction is printed on the bottom of the receipt to indicate clerks 1 through 10. For example:

```

|| 16:36           03-01-2006 ||
|| 000057      CLERK 1           00 ||
  
```

See “**Clerk Operations**” for clerk sign on and sign off sequences.

Programming a Clerk Code

The clerk code consists of a three digit secret number, followed by the digit representing the number of the clerk.

1. Turn the control lock to the **PGM** position.
2. Set system option #16 to a value of **1** or **2** (for with a stay down or pop-up mode). See “**System Option Programming**”.
3. Enter the clerk number (1-10) or the secret code number
4. Press the **CLERK** key.
5. Enter a three digit secret code,
6. Press the **X/TIME** key.
7. Repeat from step 3 to 6 for each clerk you wish to program.
8. Press the **CASH/TEND** key to end programming.

Clerk Programming Flowchart

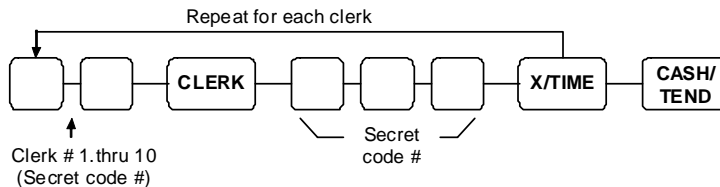

Clerk Programming Example

To set Clerk 5 with a code of 5 6 7, enter:

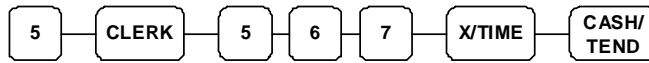

Printing Clerk Codes:

If you need to verify clerk codes:

1. Turn the control lock to the **PGM** position.
2. Press the **CLERK** key.
3. The printer will print as in the example below:

THANK YOU CALL AGAIN	
CLERK 1	1
CLERK 2	2
CLERK 3	3
CLERK 4	4
CLERK 5	567
CLERK 6	6
CLERK 7	7
CLERK 8	8
CLERK 9	9
CLERK 10	10
PROGRAM TERMINATE	
16:36	03-01-2006
000058	00

Changing the Secret Clerk Code.

You can change the existing secret code of a clerk.

By inputting the old secret No. followed by the new secret No. of the clerk.

* If you inputting 0 in a New Secret code #, the secret No. of the clerk is initialized to the clerk number.

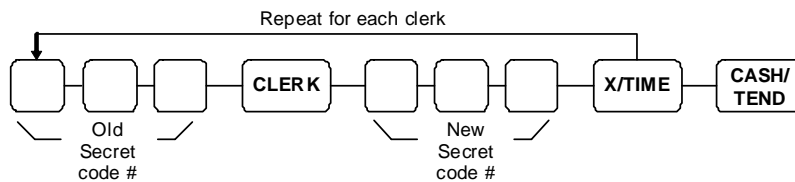

Register Number Programming

You can program a two digit register number that will print on the lower right corner of each transaction. If you are using more than one cash register, the register number can be used to identify the register where the transaction was entered.

THANK YOU CALL AGAIN	
MACHINE NO.	99
PROGRAM TERMINATE	
16:36	03-01-2006
000059	99

Register Number

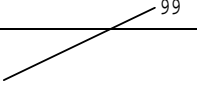

To set a register identification number:

1. Turn the control lock to the **PGM** position.
2. Enter register number and press the **#/NS** key:



3. Press the **CASH/TEND** key to end programming.



Descriptor Programming

Alpha Overlay Method

Using the Overlay layout - EPROM v1.013A and Later

1. According to the Alpha overlay, find the character you wish to print.
2. Press the bottom with the character you need.

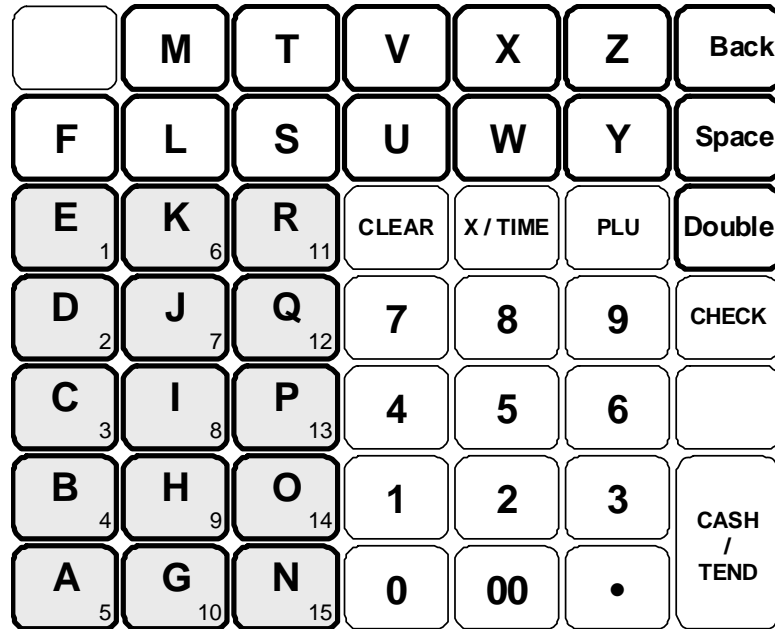

Using the Overlay layout - EPROM v1.010 and Earlier

1. Find the key that has the character you need.
2. According to the order on the key in the overlay below, press once will give you the first character, press twice will give you the second character, press three times will give you the last character.

For example, press Department 7 key once will give you an 'M', twice will give you an 'N', three times will give you an 'O'.

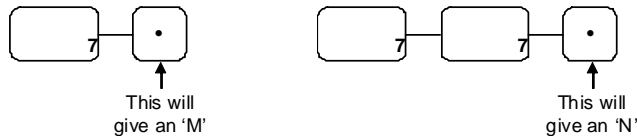

Another example, press Department 15 key once will give a '%', twice will give you an "'", three times will give you an '('.

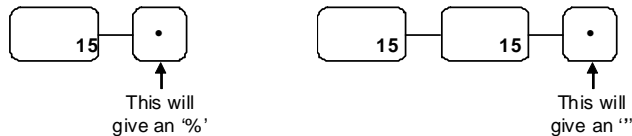

3. If there is any number used in the descriptor, just press the numerical key once.
4. With any character, symbol and number, a decimal point '.' is needed to follow up.

		Space	Double	Ü £ Ñ	Ø Á €	Í Ó Ú
) * +	, - sp	^ ~	\ { }	_ . Dbl	Ç Ä Å	É Æ Ö
ABC 1	DEF 6	GHI 11	CLEAR	X / TIME	PLU	
JKL 2	MNO 7	PQR 12	7	8	9	CHECK
STU 3	VWX 8	YZ@ 13	4	5	6	
& # \$ 4	% : 9	; < = 14	1	2	3	CASH / TEND
> ? [5] ! " 10	% '(15	0		.	

Code Table Method

Using the Code Table

1. Find the character you wish to print.
2. Find the first entry digit for the character by following the column to the top of the table.
3. Find the second entry digit for the character by following the row to the left margin of the table.

For example, enter code “1 4” for character “4”, code “2 0” for character “A”, and code “4 5” for character “Z”.

		First Entry								
		1	2	3	4	5	6	7	8	9
Second Entry	0	0	A	K	U	•	!	SPACE	Ç	À
	1	1	B	L	V	/	"		Ä	€
	2	2	C	M	W	:	%	^	Å	í
	3	3	D	N	X	;	'	~	É	Ó
	4	4	E	O	Y	<	(\	Æ	Ú
	5	5	F	P	Z	=)	{	Ö	
	6	6	G	Q	@	>	*	}	Ü	
	7	7	H	R	&	?	+	-	£	
	8	8	I	S	#	[,	.	Ñ	
	9	9	J	T	\$]	-	DEL WIDTH	Ø	

Customer Logo Descriptor

Without otherwise programming, the customer logo will print a two line message at the top of each receipt:

THANK YOU CALL AGAIN

If you wish you can replace this message with your own custom message. Your message can be up to 6 lines long. (see “Alpha Program Overlay”)

Programming a Custom Logo:

1. Turn the control lock to the **PGM** position.
2. Press the **X/TIME** key.
3. Enter up to **32 characters** for a line of the logo
 - * For **EPROM v1.013A and after**, refer to **NEW Alpha Overlay**, enter the character you wish, **or**
 - * For **EPROM v1.010 and before**, refer to **OLD Alpha Overlay**, enter the character you wish, **each character follow up with decimal point ‘.’**, or
 - * Refer to the **Code Table**, enter the two digits that represent each character you wish.
4. Press the **X/TIME** key.
5. Enter the two digit number that represents the line of the message you wish to program:

Line# Code	Line Content	Line# Code	Line Content
11	1 st Line Preamble Logo	21	1 st Line Postamble Logo
12	2 nd Line Preamble Logo	22	2 nd Line Postamble Logo
13	3 rd Line Preamble Logo	23	3 rd Line Postamble Logo
14	4 th Line Preamble Logo	24	4 th Line Postamble Logo
15	5 th Line Preamble Logo	25	5 th Line Postamble Logo
16	6 th Line Preamble Logo	26	6 th Line Postamble Logo

6. Press the **CHECK** key
7. Repeat from step 2 to 6 for each line you are programming.
8. Press the **CASH/TEND** key to end programming.

Logo Descriptor Programming Flowchart

Repeat for each Line of the Logo

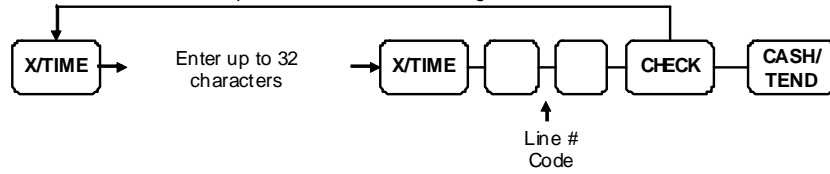

(v1.011 & after)

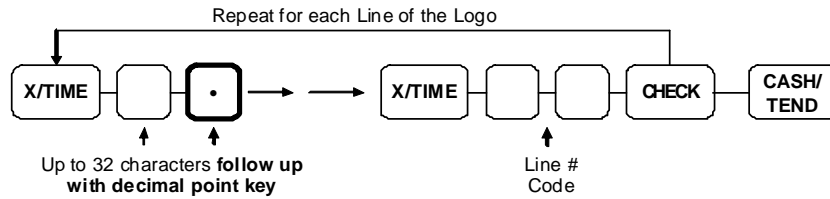

(v1.010 & before)

or

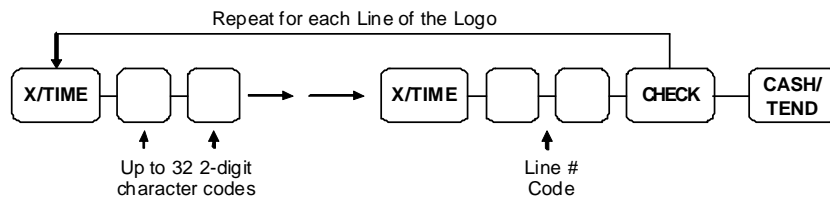

Department Descriptor

Without otherwise programming, each department will print the department number for registrations and reporting. (see “Alpha Program Overlay”)

For example, the receipt will look like this:

DEPT.1	T1	\$2.99
DEPT.7	T1	\$1.99

If you wish you can each department descriptor with a custom descriptor, up to 18 characters in length. For example, you could program your own descriptors like this:

GRECERY	T1	\$2.99
MEAT	T1	\$1.99

Programming a Department Descriptor

1. Turn the control lock to the **PGM** position.
2. Press the **X/TIME** key.
3. Enter up to **18 characters** for a department.
 - * For **EPROM v1.013A and after**, refer to *NEW Alpha Overlay*, enter the character you wish, **or**
 - * For **EPROM v1.010 and before**, refer to *OLD Alpha Overlay*, enter the character you wish, **each character follow up with decimal point ‘.’**, or
 - * Refer to the **Code Table**, enter the two digits that represent each character you wish.
4. Press the **X/TIME** key.
5. Press the department key you programmed for.
6. Repeat from step 2 to 5 for next department you want to program.
7. Press the **CASH/TEND** key to end programming.

Department Descriptor Programming Flowchart

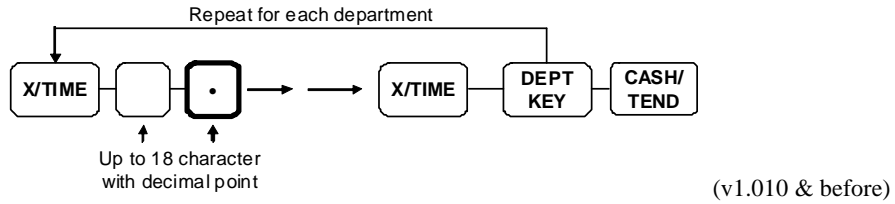
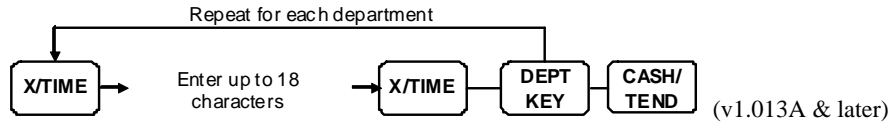

or

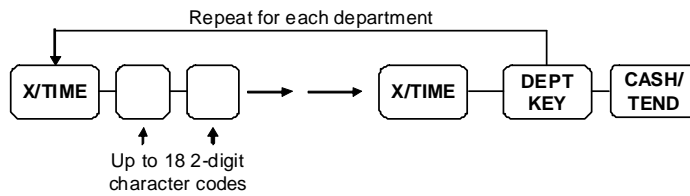

PLU Descriptor

If you are using PLUs, the PLU descriptor print the PLU code unless you choose to program a custom descriptor. (see “Alpha Program Overlay”)

For example, the receipt will look like this:

PLU1	T1	\$2.99
PLU23	T1	\$1.99

If you wish you can each department descriptor with a custom descriptor, up to 18 characters in length. For example, you could program your own descriptors like this:

CIGARETTE	T1	\$2.99
APPLES	T1	\$1.99

Programming a PLU Descriptor

1. Turn the control lock to the **PGM** position.
2. Press the **X/TIME** key.
3. Enter up to **18 characters** for a PLU,
 - For **EPROM v1.013A and after**, refer to **NEW Alpha Overlay**, enter the character you wish, **or**
 - For **EPROM v1.010 and before**, refer to **OLD Alpha Overlay**, enter the character you wish, **each character follow up with decimal point ‘.’**, or
 - Refer to the **Code Table**, enter the two digits that represent each character you wish.
4. Press the **X/TIME** key.
5. Enter the PLU number, press the **PLU** key.
6. Repeat from step 2 to 5 for next PLU you want to program.
7. Press the **CASH/TEND** key to end programming.

PLU Descriptor Programming Flowchart

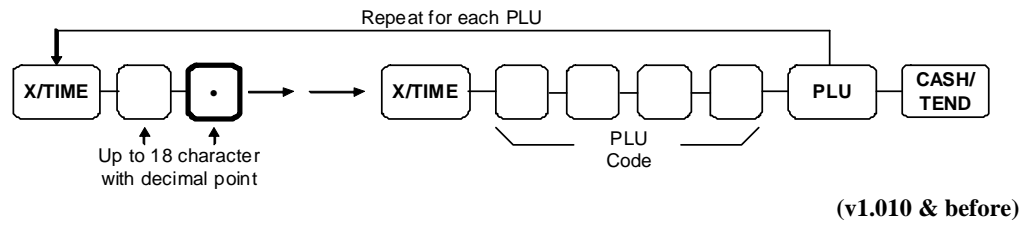
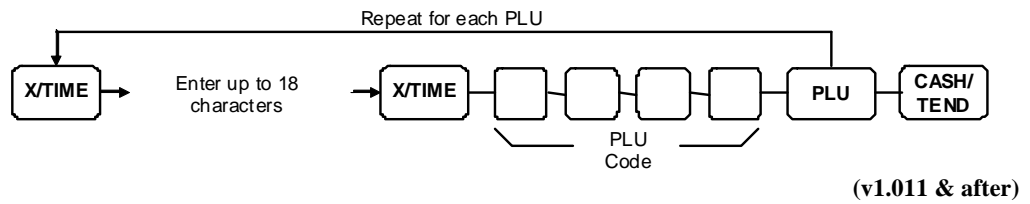

or

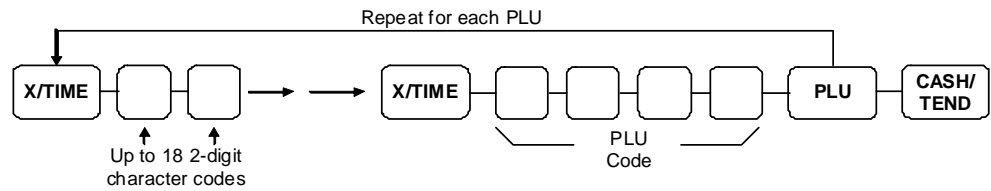

Descriptor Programming Example

For **Customer Logo Descriptor**, **Department Descriptor** and **PLU Descriptor**, the example key sequence between X/TIME keys is shown below. Please note the different between new (**EPROM v01.013A and later**) and previous (**EPROM v01.010 and earlier**).

In the example, those boxes with pattern indicate the length of description has exceed 18 charactors and only capable with Logo Descriptor.

To program descripton **APPLE HOUSE**, the key sequence will be:

- Using new alpha overlay entry method (**EPROM v01.013A and later**)

For **SINGLE SIZE**

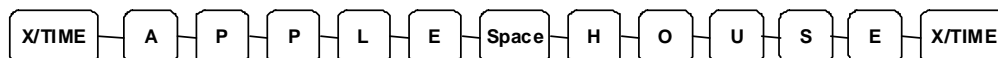

For **DOUBLE SIZE**

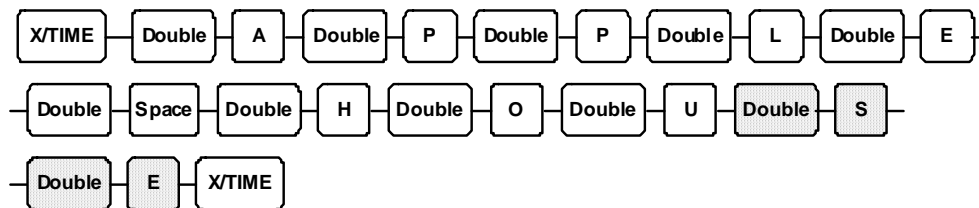

- Using previous alpha overlay entry method (**EPROM v01.010 and before**)

For **SINGLE SIZE**

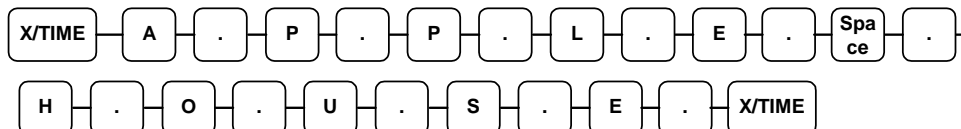

For **DOUBLE SIZE**

Note: "Double" also apply to Department and PLU descriptors.

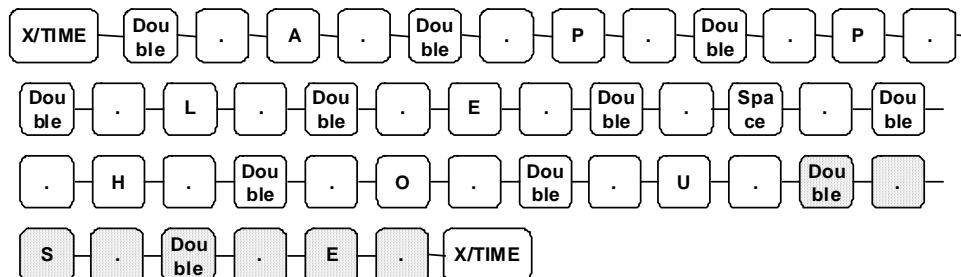

- Using two digit code entry method

In **SINGLE SIZE**, Enter the codes “2 0 3 5 3 5 3 1 2 4 7 0” representing the text.

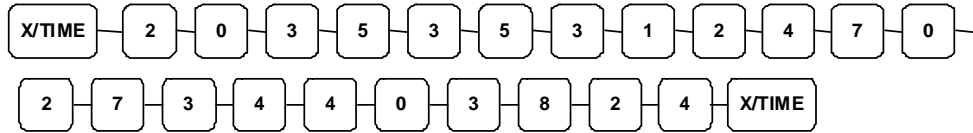

In **DOUBLE SIZE**, Enter the codes “7 9 2 0 7 9 3 5 7 9 3 1 7 9 2 4 7 9 7 0 7 9 2 7 7 9 3 4 7 9 4 0 7 9 3 8 7 9 2 4” representing the text.

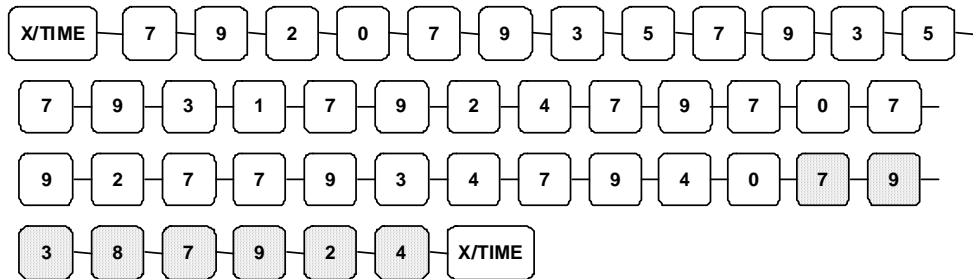

Program Scan

Department and Option Program Scan

You can generate a print of all the programming options scan.

1. Turn the control lock to the **PGM** position.
2. Press the **CASH/TEND** key to print the program report.

PLU Programming Scan

You can generate PLU PROGRAM SCAN.

1. Turn the control lock to the **PGM** position
2. Enter 15 on the numeric keypad and press the **SUB TOTAL** key.
3. To read PLU program information, enter the number(1-1000) of the start PLU and press the **PLU** key
4. To read PLU program information, enter the number(1-1000) of the end PLU and press the **PLU** key

Program Scan Example

THANK YOU CALL AGAIN		
Department Status ->	DEPT.1	70
Department Price or Limit ->		\$0.00
	DEPT.2	70
		\$0.00
	DEPT.	70
		\$0.00
(Department Status and Price/Limit is listed for each department)	.	
	DEPT.15	70
		\$0.00
Tax 1 Status ->	TAX1 STATUS	00
Tax 1 Rate ->	TAX1 RATE	0.000
Tax 2 Status ->	TAX2 STATUS	00
Tax 2 Rate ->	TAX2 RATE	0.000
Tax 3 Status ->	TAX3 STATUS	00
Tax 3 Rate ->	TAX3 RATE	0.000
Tax 4 Status ->	TAX4 STATUS	00
Tax 4 Rate ->	TAX4 RATE	0.000
Percentage Discount Key Status ->	-% STATUS	0
Percentage Discount Key Rate ->	-% RATE	0.000
Percentage Surcharge Key Status ->	+% STATUS	0
Percentage Surcharge Key Rate ->	+% RATE	0.000
Minus (-) Key Status ->	- STATUS	0
Currency Conversion Exchange Rate ->	CHANGE RATE	#0
Decimal Position ->	DECIMAL	0
System Option Value ->	OPTION1	0
System Option Value ->	OPTION2	0
System Option Value ->	OPTION3	0
(System Option Value is listed for each option)	.	
	.	
System Option Value ->	OPTION32	0
Time/Date ->	15:56	03-01-2006
Transaction Counter/Register Number ->	000066	00

Report Samples

Financial Report

NOTE: This sample report is shown with items of zero value listed on the report. Your report may only show totals with values other than zero, depending on the setting for system option #5.

Report Name ->

Report Type/Reset (X/Z) Counter -> X

Department Activity Counter -> DEPT.1

Department Sales Total -> DEPT.2

DEPT.3

DEPT.4

DEPT.5

DEPT.6

DEPT.7

DEPT.15

(Department Counters and Totals are listed for each department)

+DEPT TTL

-DEPT TTL

ADJST DEPT TTL

Total of non-taxable sales ->

THANK YOU CALL AGAIN	
< DAILY REPORT >	
X	1
DEPT.1	18.00
DEPT.2	\$33.03
DEPT.3	1.00
DEPT.4	\$0.07
DEPT.5	4.00
DEPT.6	\$50.99
DEPT.7	2.00
DEPT.15	\$3.50
.	0.00
.	\$0.00
DEPT.15	0.00
.	\$0.00

+DEPT TTL	26.00
-DEPT TTL	\$108.58
ADJST DEPT TTL	0.00
ADJST DEPT TTL	\$0.00
ADJST DEPT TTL	26.00
ADJST DEPT TTL	\$108.58

NONTAX TTL	

Continued on the next page...

Taxable sales for tax rate 1 ->	TAXABLE1	\$33.04
Tax 1 amount collected ->	TAX AMOUNT	\$1.98
Taxable sales for tax rate 2 ->	TAXABLE2	\$0.00
Tax 2 amount collected ->	TAX AMOUNT	\$0.00
Taxable sales for tax rate 3 ->	TAXABLE3	\$0.00
Tax 3 amount collected ->	TAX AMOUNT	\$0.00
Taxable sales for tax rate 4 ->	TAXABLE4	\$0.00
Tax 4 amount collected ->	TAX AMOUNT	\$0.00
Activity count for discount key ->	-%	0
Dollar amount of discounts ->		\$0.00
Activity count for surcharge key ->	+%	0
Dollar amount of surcharges ->		\$0.00
Activity count for -(MINUS) key ->	-	0
Dollar amount of -(MINUS) ->		\$0.00
Net Sales total ->	NET TOTAL	\$110.57
TAX 1 credited on negative sales ->	CREDIT TAX1	\$0.00
TAX 2 credited on negative sales ->	CREDIT TAX2	\$0.00
TAX 3 credited on negative sales ->	CREDIT TAX3	\$0.00
TAX 4 credited on negative sales ->	CREDIT TAX4	\$0.00
Count of Return Merchandise items ->	RETURN MDSE	1
Total of Return Merchandise ->		-10.00
Count of VOID key activity ->	VOID KEY	0
Total of VOID key activity ->		\$0.00
# of VOID key position transactions ->	VOID MODE	0
Dollar amount of VOID key position ->		\$0.00
# of canceled transactions ->	CANCEL	0
Amount of canceled transactions ->		\$0.00
Gross Sales Total	GROSS TTL	\$120.57
# of Cash sales ->	CASH	6
Dollar amount of Cash sales ->		\$60.59
# of Check sales ->	CHECK	2
Dollar amount of Check sales ->		19.99
# of Charge sales ->	CHARGE	1
Dollar amount of Charge sales ->		\$29.99
# of Rec'd on Account transactions ->	RECEIVED ON	2
Total of Rec'd on Accounts ->		\$30.99
# of Paid Out transactions ->	PAID OUT	1
Total of Paid Out transactions ->		\$10.00
Foreign Currency Total ->	CURRENCY TOTAL	\$0.00
Cash in drawer amount ->	CASH IN DRAWER	\$81.58
Check in drawer amount ->	CHECK IN DRAWER	\$19.99
Count of no sales ->	NO SALE COUNT	0
Customer Count ->	CUSTOMER COUNT	9
Non-resettable Grand Total ->	***** GRAND TOTAL	\$12474.83
Date /Time ->	15:59	03-01-2006
Transaction Counter/Register Number ->	000050	00

Hourly Sales Report

The Hourly sales report lists the number of transaction and their dollar total for each hour of the day.

	THANK YOU CALL AGAIN
Report Name ->	< TIME REPORT >
Report Type/Reset (X/Z) Counter	X 1
Time Period Activity Counter ->	10:00 7
Time Period Sales Total ->	\$7.59
(Counters and Totals are listed for each time period)	11:00 1
	\$346.67
	12:00 9
	\$110.57

Activity count of all time periods ->	CNT TOTAL 17
Total of all time periods ->	TOTAL \$474.83
Time/Date ->	16:05 03-01-2006
Transaction Counter/Register Number ->	000054 00

PLU Report

The PLU report lists the activity and sale total for each PLU.

Report Name ->
Report Type/Reset (X/Z) Counter
PLU Activity Counter ->
PLU tax status/PLU price or limit ->
Reporting Dept/PLU Sales Total ->
(PLU Counters and Totals are listed for each PLU)
Activity count of all PLUs ->
Total of all PLUs ->
Time/Date ->
Transaction Counter/Register Number ->

THANK YOU CALL AGAIN		
< PLU REPORT >		
X		1
PLU1		1
	T1	@1.99
DEPT.2		\$1.99
PLU30		1
	T2	@10.00
DEPT.4		\$10.00

CNT TOTAL		417
TOTAL		\$12474.83
16:07		03-01-2006
000058		00

Clerk Report

If you are using a clerk system, the clerk report is available. (See “System Option Programming” on page 64 and set option #16 to a value of **1** or **2** if you wish to use the clerk system.)

	THANK YOU CALL AGAIN
Report Name ->	< CLERK REPORT >
Report Type/Reset (X/Z) Counter	X 1
Total sales for the clerk ->	•CLERK 1 \$1.06
Number of no sales performed ->	NO SALE CNT. 0
Customer Count for the clerk ->	CUSTOM. CNT 1
(Totals are listed for each CLERK)	•CLERK 2 \$7.92
	NO SALE CNT. 0
	CUSTOM. CNT 9

Total count of all No Sales ->	NO SALE CNT. 0
Total count of all customers ->	CUSTOM. CNT 10
Total of all customers ->	TOTAL \$8.98
Time/Date ->	16:09 03-01-2006
Transaction Counter/Register Number ->	000060 00

Cash-in-Drawer Report

Run a Cash-in-Drawer report to quickly verify the amount of cash that should be in the cash drawer.

Report Name ->	THANK YOU CALL AGAIN	
	< CASH-IN-DRAWER >	
Cash in drawer amount ->	CASH-IN-DRAWER	\$81.58
Time/Date ->	16:15	03-01-2006
Transaction Counter/Register Number ->	000063	00

Check-in-Drawer Report

Run a Check-in-Drawer report to quickly verify the amount of checks that should be in the cash drawer.

Report Name ->	THANK YOU CALL AGAIN	
	< CHECK-IN-DRAWER >	
Check in drawer amount ->	CHECK-IN-DRAWER	\$19.00
Time/Date ->	16:17	03-01-2006
Transaction Counter/Register Number ->	000064	00

System Balancing

Department Sales Total

+	+DEPT TTL (Add All Positive Departments)
-	-DEPT TTL (Add All Negative Departments)
=	ADJST DEPT TTL

Net Total

+	ADJST DEPT TTL
+	TAX1 AMOUNT
+	TAX2 AMOUNT
+	TAX3 AMOUNT
+	TAX4 AMOUNT
+	+% (Surcharge Total)
-	-% (Discount Total)
-	- (Minus Key Total)
=	NET TTL

Gross Total

+	NET TTL
+	RETURN MDSE
+	VOID KEY
-	+% (Surcharge Total)
+	-% (Discount Total)
+	- (Minus Key Total)
=	GROSS TTL

Grand Total

+	Yesterdays Grand Total
+	Gross Total
=	GRAND TOTAL

JK68-60980A Rev. 3.07 (Jun 11)
From ER260/265 v01.000
Up to ER260/265 v05.000